

# FCZI P

## Fan coil unit for ducted installations

Cooling capacity 0,89 ÷ 8,60 kW  
 Heating capacity 2,02 ÷ 17,02 kW

- Electric saving equal to 50% with respect to a fan coil with 3-speed motor
- Suitable for duct-type installations too
- Total comfort: reduced variations in temperature and relative humidity
- Vertical and horizontal installation
- Very quiet



### DESCRIPTION

fan coil can be installed in any 2/4 pipe system and operates with any heat generator even at low temperatures, and thanks to varied versions and settings, it is easy to pick the ideal solution for any need.

### FEATURES

#### Ventilation group

Centrifugal fans in anti-static plastic material with aerofoil profile designed to achieve high airflows and pressures whilst at the same time producing low noise.

Their characteristics permit energy savings compared to conventional fans.

They are statically and dynamically balanced and directly coupled to the motor shaft.

The Brushless electric motor with 0-100% continuous speed variation, which allows precise adaptation to the real demands of the internal environment without temperature fluctuations.

#### Heat exchanger coil

With copper pipes and aluminium fins, the standard or oversized main coil and the possible secondary coil have female gas water connections on the left side and the manifolds have air vents.

The coil is not suitable for use in corrosive atmosphere or in environments where aluminium may be subject to corrosion.

**Reversibility of the water connections during installation only for units with a standard or boosted main coil, or standard with BV accessory. Not reversible in all other configurations. In any case, units with the coil water connections on the right are available at the time of ordering.**

#### Condensate drip

Provided standard in plastic and fixed to the interior structure; with external condensate discharge.

#### Air filter

Air filter class Coarse 25% for all versions easy to pull out and clean.

### VERSIONS

#### Flush-mounting and duct-type versions

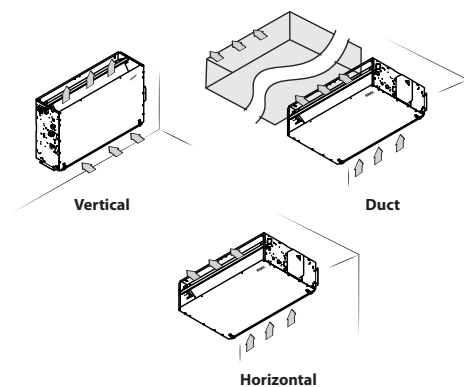

**In the standard configuration there is no useful static pressure available. If necessary for canaled installations, you must act on the engine dip switches, for more details refer to the technical documentation.**

## GUIDE TO SELECTING THE POSSIBLE CONFIGURATIONS

Field	Description
1,2,3,4	FCZI
5	Size 2, 3, 4, 5, 7, 9
6	Main coil
0	Standard
5	Oversized
7	Secondary coil

Field	Description
0	Without coil
1	Standard
2	Oversized
8	Version
P	Flush-mounting, without cabinet
PR	Flush-mounting, without cabinet, with water connections on right-hand side

## SIZE AVAILABLE FOR VERSION

Size	200	201	202	250	300	301	302	350	400	401	402	450
Versions produced (by size)												
Versions available (by size)	P,PR	.	.	.	.	.	.	.	.	.	.	.
	500	501	502	550	700	701	702	750	900	901	950	
Versions produced (by size)												
Versions available (by size)	P,PR	.	.	.	.	.	.	.	.	.	.	.

## ACCESSORIES

### Control panels

**AER503IR:** Flush-mounting thermostat with backlit display, capacitive keypad and infrared receiver, for controlling both brushless fan coils and those with an asynchronous motor. In 2-pipe systems, the thermostat can control standard fan coils or those equipped with an electric heater, with air purifying devices (Cold Plasma and germicidal lamp), with radiant plate or with FCZ-D twin delivery (Dualjet). In addition, it can control systems with radiant panels or mixed (fan coil and radiant floor) systems. Being equipped with an infrared receiver, it can, in turn, be controlled by the VMF-IR remote control.

**PRO503:** Wall box for AER503IR and VMF-E4 thermostats.

**PXAI:** Thermostat on the machine for controlling the fan coils (both with asynchronous and brushless motors), complete with water and air probes to be positioned in the relative seats, and a plastic support to fix it on the side of the unit. In 2-pipe systems, the thermostat can control standard fan coils or those equipped with an electric heater, purifier devices (Cold Plasma and germicidal lamp), or radiant plate.

**SA5:** air probe kit (L = 15 m) with probe-locking cable grommet.

**SW3:** Water probe (L = 2.5 m) for controlling the minimum and maximum and to allow automatic seasonal switching for electronic thermostats fitted with water side changeover.

**SW5:** water probe kit (L = 15m) with probe-holder connection point, fixing clip and probe-holder from heat exchanger.

**TX:** Wall-mounting thermostat for controlling either brushless fan coils or those with asynchronous motors. In 2-pipe systems, the thermostat can control standard fan coils or those equipped with an electric heater, with air purifying devices, radiant plate or FCZ-D twin delivery (Dualjet).

### VMF system

**VMF-E19I:** Thermostat for inverter unit to be fixed on the side of the fan coil, fitted as standard with an air and water probe.

**VMF-E3:** Wall mounted user interface, to be combined with accessories VMF-E19, VMF-E19I, VMF-E0X with grids GLF\_N/M and GLL\_N, can be controlled with VMF-IR control.

**VMF-E4DX:** Wall-mounted user interface. Grey front panel PANTONE 425C (METAL).

**VMF-E4X:** Wall-mounted user interface. Light grey front panel PANTONE COOL GRAY 1C.

**VMF-IR:** User interface compatible with the AER503IR thermostat and with all the grids of cassettes equipped with the infrared receiver compatible with the VMF system.

**VMF-SW:** Water temperature probe.

**VMF-SW1:** Extra water probe to be used for 4-pipe systems.

### Water valves

**VCZ\_X:** 3-way valve kit for single-coil fan coil, RH connections, for 4-pipe systems. With totally separate "heating" and "cooling" circuits. This kit consists of two 3-way insulated valves and four connections, complete with electrothermal actuators, insulating shells for the valves, and the relative hydraulic couplings. X4L version for fan coils with LH connections, and X4R for fan coils with RH connections. 230V~50Hz power supply.

**VCZ41:** 3-way motorised valve kit. The kit consists of a valve with its insulating shell, an actuator and the relative pipe fittings. It can be installed on fan coils with both right and left connections.

**VCZ4124:** 3-way motorised valve kit. The kit consists of a valve with its insulating shell, an actuator and the relative pipe fittings. It can be installed on fan coils with both right and left connections.

**VCZ42:** 3-way motorised valve kit. The kit consists of a valve with its insulating shell, an actuator and the relative pipe fittings. It can be installed on fan coils with both right and left connections.

**VCZ4224:** 3-way motorised valve kit. The kit consists of a valve with its insulating shell, an actuator and the relative pipe fittings. It can be installed on fan coils with both right and left connections.

**VCZ43:** 3-way motorised valve kit. The kit consists of a valve with its insulating shell, an actuator and the relative pipe fittings. It can be installed on fan coils with both right and left connections.

**VCZ4324:** 3-way motorised valve kit. The kit consists of a valve with its insulating shell, an actuator and the relative pipe fittings. It can be installed on fan coils with both right and left connections.

**VCF44 - 45 - for the secondary coil:** The 3-way motorised valve kit for the secondary coil or an optional heat only coil. The kit consists of a valve with its insulating shell, actuator and relevant water fittings; it is suitable to be installed on the fan coils with right and left water connections.

**VCZD:** 2-way motorised valve kit. The kit consists of a valve, an actuator and the relative pipe fittings. It can be installed on fan coils with both right and left connections.

**VJP:** Control and balancing combination valve for 2 and 4 pipe systems to install outside the unit, supplied without fittings and hydraulic components. The valve, which can guarantee a constant water flow rate in the terminal, within its operating range.

### (Heating only) additional coil

**BV:** Single row hot water heat exchanger.

### Installation accessories

**AMP:** Wall mounting kit

**DSC:** Condensate drainage device.

**BC:** Condensate drip.

**BCZ:** Condensate drip.

**Ventilcassaforma:** Galvanised sheet metal template. It makes it possible to obtain directly in the wall a space for housing the fan coil.

**GA:** Intake grid with fixed louvers

**GAF:** Intake grid with filter and fixed louvers

**GM:** Flow grid with adjustable louvers.

**PA:** Intake plenum in galvanised sheet metal, complete with suction couplings for circular-section ducts.

**PAF:** Intake plenum providing recovery and delivery on the same side, for all installations where the machine needs to be positioned outside the air conditioned rooms to minimise the noise levels and facilitate maintenance.

**PM:** Delivery plenum with circular flanges. Sandwich structure in hot galvanised steel, with interposed polyurethane foam (40 kg/m3). The

panel is 15 mm thick. It is installed in place of the delivery panel with a rectangular flange, using the same 4 self-threading screws.

**RD:** Straight delivery coupling for canalisation.

**RDA:** Straight suction coupling for canalisation.

**RP:** 90° delivery coupling.

**RPA:** 90° suction coupling.

### Accessories for ducting

**MZC:** Plenum with motorised dampers.

**RDA\_V:** Straight intake connection with rectangular flange.

**RPA\_V:** Suction plenum with rectangular flange; both sides have a circular push-out Ø 150mm that can be removed.

**RDA\_C:** Straight intake connection with circular flanges.

**PA\_V:** Suction plenum with circular plastic flanges; both sides have a circular push-out Ø 150mm that can be removed.

**PM\_V:** Internally insulated delivery plenum with circular flanges; both sides have a circular push-out Ø 150mm that can be removed.

**RPM\_V:** Internally insulated delivery plenum with rectangular flange; both sides have a circular push-out Ø 150mm that can be removed.

**RDM\_V:** Straight delivery coupling in galvanised sheet metal.

**RDM\_C:** Straight discharge internally insulated, with circular flanges.

## ACCESSORIES COMPATIBILITY

### Control panels

Model	Ver	200	201	202	250	300	301	302	350	400	401	402	450	500	501	502	550	700	701	702	750	900	901	950
AER503IR (1)	P,PR	.	.	.	.	.	.	.	.	.	.	.	.	.	.	.	.	.	.	.	.	.	.	.
PRO503	P,PR	.	.	.	.	.	.	.	.	.	.	.	.	.	.	.	.	.	.	.	.	.	.	.
PXAI	P,PR	.	.	.	.	.	.	.	.	.	.	.	.	.	.	.	.	.	.	.	.	.	.	.
SAS (2)	P,PR	.	.	.	.	.	.	.	.	.	.	.	.	.	.	.	.	.	.	.	.	.	.	.
SW3 (2)	P,PR	.	.	.	.	.	.	.	.	.	.	.	.	.	.	.	.	.	.	.	.	.	.	.
SW5 (2)	P,PR	.	.	.	.	.	.	.	.	.	.	.	.	.	.	.	.	.	.	.	.	.	.	.
TX (1)	P,PR	.	.	.	.	.	.	.	.	.	.	.	.	.	.	.	.	.	.	.	.	.	.	.

(1) Wall-mount installation.

(2) Probe for AER503IR-TX thermostats, if fitted.

### VMF system

For more information about VMF system, refer to the dedicated documentation.

#### VMF system

Model	Ver	200	201	202	250	300	301	302	350	400	401	402	450	500	501	502	550	700	701	702	750	900	901	950
VMF-E19I	P,PR	.	.	.	.	.	.	.	.	.	.	.	.	.	.	.	.	.	.	.	.	.	.	.
VMF-E3	P,PR	.	.	.	.	.	.	.	.	.	.	.	.	.	.	.	.	.	.	.	.	.	.	.
VMF-E4DX	P,PR	.	.	.	.	.	.	.	.	.	.	.	.	.	.	.	.	.	.	.	.	.	.	.
VMF-E4X	P,PR	.	.	.	.	.	.	.	.	.	.	.	.	.	.	.	.	.	.	.	.	.	.	.
VMF-IR	P,PR	.	.	.	.	.	.	.	.	.	.	.	.	.	.	.	.	.	.	.	.	.	.	.
VMF-SW	P,PR	.	.	.	.	.	.	.	.	.	.	.	.	.	.	.	.	.	.	.	.	.	.	.
VMF-SW1	P,PR	.	.	.	.	.	.	.	.	.	.	.	.	.	.	.	.	.	.	.	.	.	.	.

### Water valves

#### Valve Kit for 4 pipe systems - Requires a thermostat with valve management

Model	Ver	200	201	202	250	300	301	302	350	400	401	402	450	500	501	502	550	700	701	702	750	900	901	950
VCZ1X4L (1)	P,PR	.	.	.	.	.	.	.	.	.	.	.	.	.	.	.	.	.	.	.	.	.	.	.
VCZ1X4R (1)	P,PR	.	.	.	.	.	.	.	.	.	.	.	.	.	.	.	.	.	.	.	.	.	.	.
VCZ2X4L (1)	P,PR	.	.	.	.	.	.	.	.	.	.	.	.	.	.	.	.	.	.	.	.	.	.	.
VCZ2X4R (1)	P,PR	.	.	.	.	.	.	.	.	.	.	.	.	.	.	.	.	.	.	.	.	.	.	.
VCZ3X4L (1)	P,PR	.	.	.	.	.	.	.	.	.	.	.	.	.	.	.	.	.	.	.	.	.	.	.
VCZ3X4R (1)	P,PR	.	.	.	.	.	.	.	.	.	.	.	.	.	.	.	.	.	.	.	.	.	.	.

(1) The valves can be combined with the units if there is a control panel for managing them.

#### 3 way valve kit

	200	201	202	250	300	301	302	350	400	401	402	450
<b>Main coil</b>	VCZ41	VCZ41	VCZ41	VCZ41	VCZ42	VCZ42	VCZ42	VCZ42	VCZ42	VCZ42	VCZ42	VCZ42
	VCZ4124	VCZ4124	VCZ4124	VCZ4124	VCZ4224	VCZ4224	VCZ4224	VCZ4224	VCZ4224	VCZ4224	VCZ4224	VCZ4224
<b>Secondary coil</b>	-	VCF44	VCF44	-	-	VCF44	VCF44	-	-	VCF44	VCF44	-
	-	VCF4424	VCF4424	-	-	VCF4424	VCF4424	-	-	VCF4424	VCF4424	-
<b>Additional coil "BV"</b>	VCF44	-	-	-	VCF44	-	-	-	VCF44	-	-	-
	VCF4424	-	-	-	VCF4424	-	-	-	VCF4424	-	-	-
<b>Main coil</b>	VCZ42	VCZ42	VCZ42	VCZ42	VCZ42	VCZ42	VCZ42	VCZ42	VCZ42	VCZ43	VCZ43	VCZ43
	VCZ4224	VCZ4224	VCZ4224	VCZ4224	VCZ4224	VCZ4224	VCZ4224	VCZ4224	VCZ4224	VCZ4324	VCZ4324	VCZ4324
<b>Secondary coil</b>	-	VCF44	VCF44	-	-	VCF44	VCF44	-	-	VCF45	VCF45	-
	-	VCF4424	VCF4424	-	-	VCF4424	VCF4424	-	-	VCF4524	VCF4524	-
<b>Additional coil "BV"</b>	VCF44	-	-	-	VCF44	-	-	-	VCF45	-	-	-
	VCF4424	-	-	-	VCF4424	-	-	-	VCF4524	-	-	-

2 way valve kit

	200	201	202	250	300	301	302	350	400	401	402	450
<b>Main coil</b>	VCZD1	VCZD1	VCZD1	VCZD1	VCZD2	VCZD2	VCZD2	VCZD2	VCZD2	VCZD2	VCZD2	VCZD2
	VCZD124	VCZD124	VCZD124	VCZD124	VCZD224	VCZD224	VCZD224	VCZD224	VCZD224	VCZD224	VCZD224	VCZD224
<b>Secondary coil</b>	-	VCFD4	VCFD4	-	-	VCFD4	VCFD4	-	-	VCFD4	VCFD4	-
	-	VCFD424	VCFD424	-	-	VCFD424	VCFD424	-	-	VCFD424	VCFD424	-
<b>Additional coil "BV"</b>	VCFD4	-	-	-	VCFD4	-	-	-	VCFD4	-	-	-
	VCFD424	-	-	-	VCFD424	-	-	-	VCFD424	-	-	-

	500	501	502	550	700	701	702	750	900	901	950
<b>Main coil</b>	VCZD2	VCZD2	VCZD2	VCZD2	VCZD2	VCZD2	VCZD2	VCZD2	VCZD3	VCZD3	VCZD3
	VCZD224	VCZD224	VCZD224	VCZD224	VCZD224	VCZD224	VCZD224	VCZD224	VCZD324	VCZD324	VCZD324
<b>Secondary coil</b>	-	VCFD4	VCFD4	-	-	VCFD4	VCFD4	-	-	VCFD4	-
	-	VCFD424	VCFD424	-	-	VCFD424	VCFD424	-	-	VCFD424	-
<b>Additional coil "BV"</b>	VCFD4	-	-	-	VCFD4	-	-	-	VCFD4	-	-
	VCFD424	-	-	-	VCFD424	-	-	-	VCFD424	-	-

**Combined Adjustment and Balancing Valve Kit**

Model	Ver	200	201	202	250	300	301	302	350	400	401	402	450	500	501	502	550	700	701	702	750	900	901	950
VJP060 (1)	P,PR	.	.	.	.	.	.	.	.	.	.	.	.	.	.	.	.	.	.	.	.	.	.	.
VJP060M (2)	P,PR	.	.	.	.	.	.	.	.	.	.	.	.	.	.	.	.	.	.	.	.	.	.	.
VJP090 (1)	P,PR	.	.	.	.	.	.	.	.	.	.	.	.	.	.	.	.	.	.	.	.	.	.	.
VJP090M (2)	P,PR	.	.	.	.	.	.	.	.	.	.	.	.	.	.	.	.	.	.	.	.	.	.	.
VJP150 (1)	P,PR	.	.	.	.	.	.	.	.	.	.	.	.	.	.	.	.	.	.	.	.	.	.	.
VJP150M (2)	P,PR	.	.	.	.	.	.	.	.	.	.	.	.	.	.	.	.	.	.	.	.	.	.	.

(1) 230V~50Hz  
(2) 24V

**(Heating only) additional coil**

**Heating only additional coil**

Model	Ver	200	201	202	250	300	301	302	350	400	401	402	450	500	501	502	550	700	701	702	750	900	901	950
BV122 (1)	P,PR	.																						
BV132 (1)	P,PR					.																		
BV142 (1)	P,PR									.														
BV162 (1)	P,PR																						.	
BV2800 (1)	P,PR																	.						

(1) Not available for sizes with oversized main coil.

**Installation accessories**

**Wall mounting kit**

Model	Ver	200	201	202	250	300	301	302	350	400	401	402	450	500	501	502	550	700	701	702	750	900	901	950
AMP20	P,PR	.	.	.	.	.	.	.	.	.	.	.	.	.	.	.	.	.	.	.	.	.	.	.
AMPZ	P,PR	.	.	.	.	.	.	.	.	.	.	.	.	.	.	.	.	.	.	.	.	.	.	.

**Condensate drip**

Model	Ver	200	201	202	250	300	301	302	350	400	401	402	450	500	501	502	550	700	701	702	750	900	901	950
BC24 (1)	P,PR	.	.	.	.	.	.	.	.	.	.	.	.	.	.	.	.	.	.	.	.	.	.	.
BC25 (2)	P,PR	.	.	.	.	.	.	.	.	.	.	.	.	.	.	.	.	.	.	.	.	.	.	.
BC26 (2)	P,PR	.	.	.	.	.	.	.	.	.	.	.	.	.	.	.	.	.	.	.	.	.	.	.

(1) For vertical installation.  
(2) For horizontal installation.

Model	Ver	200	201	202	250	300	301	302	350	400	401	402	450	500	501	502	550	700	701	702	750	900	901	950
BC8 (1)	P,PR	.	.	.	.	.	.	.	.	.	.	.	.	.	.	.	.	.	.	.	.	.	.	.
BC9 (1)	P,PR	.	.	.	.	.	.	.	.	.	.	.	.	.	.	.	.	.	.	.	.	.	.	.

(1) For horizontal installation.

**Condensate recirculation device**

Model	Ver	200	201	202	250	300	301	302	350	400	401	402	450	500	501	502	550	700	701	702	750	900	901	950
DSC24 (1)	P,PR	.	.	.	.	.	.	.	.	.	.	.	.	.	.	.	.	.	.	.	.	.	.	.

(1) DSC4 cannot be mounted if even just one of these accessories is also installed: AMP - AMPZ valve VCZ1-2-3-4 X4L/R and all the condensate collection trays.

**Ventilcassaforma**

Model	Ver	200	201	202	250	300	301	302	350	400	401	402	450	500	501	502	550	700	701	702	750	900	901	950
CHF22	P,PR	.	.	.	.																			
CHF32	P,PR					.	.	.	.															
CHF42	P,PR									.	.	.	.	.	.	.	.	.	.	.	.	.	.	.
CHF62	P,PR																	.	.	.	.	.	.	.

**Wall mounting and duct type installation accessories**

**Lower intake grille**

Model	Ver	200	201	202	250	300	301	302	350	400	401	402	450	500	501	502	550	700	701	702	750	900	901	950
GA22	P,PR	.	.	.	.																			

Model	Ver	200	201	202	250	300	301	302	350	400	401	402	450	500	501	502	550	700	701	702	750	900	901	950
GA32	PPR					.	.	.	.															
GA42	PPR									.	.	.	.	.	.	.	.							
GA62	PPR																	.	.	.	.	.	.	.

**Intake grilles with fixed fins and filter**

Model	Ver	200	201	202	250	300	301	302	350	400	401	402	450	500	501	502	550	700	701	702	750	900	901	950
GAF22	PPR	.	.	.	.																			
GAF32	PPR					.	.	.	.															
GAF42	PPR									.	.	.	.	.	.	.	.							
GAF62	PPR																	.	.	.	.	.	.	.

**Delivery grilles with adjustable fins**

Model	Ver	200	201	202	250	300	301	302	350	400	401	402	450	500	501	502	550	700	701	702	750	900	901	950
GM22	PPR	.	.	.	.																			
GM32	PPR					.	.	.	.															
GM42	PPR									.	.	.	.	.	.	.	.							
GM62	PPR																	.	.	.	.	.	.	.

**Intake plenum in sheet metal complete with connectors for circular channels**

Model	Ver	200	201	202	250	300	301	302	350	400	401	402	450	500	501	502	550	700	701	702	750	900	901	950
PA22	PPR	.	.	.	.																			
PA32	PPR					.	.	.	.															
PA42	PPR									.	.	.	.	.	.	.	.							
PA62	PPR																	.	.	.	.	.	.	.

**Intake plenum providing recovery and delivery on the same side**

Model	Ver	200	201	202	250	300	301	302	350	400	401	402	450	500	501	502	550	700	701	702	750	900	901	950
PA22F	PPR	.	.	.	.																			
PA32F	PPR					.	.	.	.															
PA42F	PPR									.	.	.	.	.	.	.	.							
PA62F	PPR																	.	.	.	.	.	.	.

**Delivery plenum with circular flanges.**

Model	Ver	200	201	202	250	300	301	302	350	400	401	402	450	500	501	502	550	700	701	702	750	900	901	950
PM22	PPR	.	.	.	.																			
PM32	PPR					.	.	.	.															
PM42	PPR									.	.	.	.	.	.	.	.							
PM62	PPR																	.	.	.	.	.	.	.

**Straight delivery coupling**

Model	Ver	200	201	202	250	300	301	302	350	400	401	402	450	500	501	502	550	700	701	702	750	900	901	950
RD22	PPR	.	.	.	.																			
RD32	PPR					.	.	.	.															
RD42	PPR									.	.	.	.	.	.	.	.							
RD62	PPR																	.	.	.	.	.	.	.

**Straight suction coupling**

Model	Ver	200	201	202	250	300	301	302	350	400	401	402	450	500	501	502	550	700	701	702	750	900	901	950
RDA22	PPR	.	.	.	.																			
RDA32	PPR					.	.	.	.															
RDA42	PPR									.	.	.	.	.	.	.	.							
RDA62	PPR																	.	.	.	.	.	.	.

**90° delivery coupling.**

Model	Ver	200	201	202	250	300	301	302	350	400	401	402	450	500	501	502	550	700	701	702	750	900	901	950
RP22	PPR	.	.	.	.																			
RP32	PPR					.	.	.	.															
RP42	PPR									.	.	.	.	.	.	.	.							
RP62	PPR																	.	.	.	.	.	.	.

**90° suction coupling.**

Model	Ver	200	201	202	250	300	301	302	350	400	401	402	450	500	501	502	550	700	701	702	750	900	901	950
RPA22	PPR	.	.	.	.																			
RPA32	PPR					.	.	.	.															
RPA42	PPR									.	.	.	.	.	.	.	.							
RPA62	PPR																	.	.	.	.	.	.	.

## Accessories for ducting

### Plenum with motorised dampers.

Model	Ver	200	201	202	250	300	301	302	350	400	401	402	450	500	501	502	550	700	701	702	750	900	901	950
MZC220	PPR	.	.	.	.																			
MZC320	PPR					.	.	.	.															
MZC530	PPR									.	.	.	.	.	.	.	.							
MZC830	PPR																	.	.	.	.	.	.	.

### Straight intake connection with rectangular flange.

Model	Ver	200	201	202	250	300	301	302	350	400	401	402	450	500	501	502	550	700	701	702	750	900	901	950
RDA000V	PPR	.	.	.	.																			
RDA100V	PPR					.	.	.	.															
RDA200V	PPR									.	.	.	.	.	.	.	.							
RDA300V	PPR																	.	.	.	.	.	.	.

### Intake plenum with rectangular flange.

Model	Ver	200	201	202	250	300	301	302	350	400	401	402	450	500	501	502	550	700	701	702	750	900	901	950
RPA100V	PPR					.	.	.	.															
RPA200V	PPR									.	.	.	.	.	.	.	.							
RPA300V	PPR																	.	.	.	.	.	.	.

### Suction plenum with plastic circular flanges.

Model	Ver	200	201	202	250	300	301	302	350	400	401	402	450	500	501	502	550	700	701	702	750	900	901	950
PA000V	PPR	.	.	.	.																			
PA100V	PPR					.	.	.	.															
PA300V	PPR									.	.	.	.	.	.	.	.	.	.	.	.	.	.	.

### Internally insulated delivery plenum with circular flanges.

Model	Ver	200	201	202	250	300	301	302	350	400	401	402	450	500	501	502	550	700	701	702	750	900	901	950
PM000V	PPR	.	.	.	.																			
PM100V	PPR					.	.	.	.															
PM300V	PPR									.	.	.	.	.	.	.	.	.	.	.	.	.	.	.

### Internally insulated delivery plenum with rectangular flange.

Model	Ver	200	201	202	250	300	301	302	350	400	401	402	450	500	501	502	550	700	701	702	750	900	901	950
RPM000V	PPR	.	.	.	.																			
RPM100V	PPR					.	.	.	.															
RPM300V	PPR									.	.	.	.	.	.	.	.	.	.	.	.	.	.	.

### Straight delivery coupling in galvanised sheet metal.

Model	Ver	200	201	202	250	300	301	302	350	400	401	402	450	500	501	502	550	700	701	702	750	900	901	950
RDM000V	PPR	.	.	.	.																			
RDM100V	PPR					.	.	.	.															
RDM300V	PPR									.	.	.	.	.	.	.	.	.	.	.	.	.	.	.

### Straight discharge internally insulated, with circular flanges.

Model	Ver	200	201	202	250	300	301	302	350	400	401	402	450	500	501	502	550	700	701	702	750	900	901	950
RDMC000V	PPR	.	.	.	.																			
RDMC100V	PPR					.	.	.	.															
RDMC300V	PPR									.	.	.	.	.	.	.	.	.	.	.	.	.	.	.

## PERFORMANCE DATA FOR UNITS WITHOUT HEAD (EUROVENT CERTIFICATE FC-H)

### 2-pipe

	FCZI200P			FCZI250P			FCZI300P			FCZI350P			FCZI400P			FCZI450P					
	1	2	3	1	2	3	1	2	3	1	2	3	1	2	3	1	2	3			
	L	M	H	L	M	H	L	M	H	L	M	H	L	M	H	L	M	H			
<b>Heating performance 70 °C / 60 °C (1)</b>																					
Heating capacity	kW			2,02	2,95	3,70	2,20	3,18	4,05	3,47	4,46	5,50	3,77	4,92	6,15	4,32	5,74	7,15	4,57	6,29	7,82
Water flow rate system side	l/h			177	258	324	193	278	355	304	391	482	330	431	539	379	503	627	400	551	685
Pressure drop system side	kPa			6	12	18	7	15	23	7	12	18	8	14	20	9	16	24	6	11	16
<b>Heating performance 45 °C / 40 °C (2)</b>																					
Heating capacity	kW			1,00	1,46	1,84	1,09	1,58	2,01	1,72	2,21	2,73	1,87	2,44	3,06	2,14	2,85	3,55	2,27	3,12	3,88
Water flow rate system side	l/h			174	254	319	190	274	350	299	385	475	325	425	531	373	495	617	394	543	675
Pressure drop system side	kPa			6	12	18	8	15	22	8	12	18	8	14	20	10	16	24	6	11	16
<b>Cooling performance 7 °C / 12 °C (3)</b>																					
Cooling capacity	kW			0,89	1,28	1,60	1,06	1,55	1,94	1,68	2,17	2,65	1,89	2,46	3,02	2,20	2,92	3,60	2,41	3,21	4,03
Sensible cooling capacity	kW			0,71	1,05	1,33	0,79	1,20	1,52	1,26	1,65	2,04	1,33	1,76	2,18	1,59	2,14	2,67	1,69	2,30	2,90
Water flow rate system side	l/h			153	221	275	182	267	334	288	374	456	350	460	560	379	503	619	414	552	694
Pressure drop system side	kPa			6	12	18	8	17	25	8	13	18	11	18	25	10	16	24	9	15	22
<b>Fan</b>																					
Type	type			Centrifugal																	
Fan motor	type			Inverter																	
Number	no.			1			1			2			2			2			2		
Air flow rate	m <sup>3</sup> /h			140	220	290	140	220	290	260	350	450	260	350	450	330	460	600	330	460	600
Input power	W			7	8	14	7	8	14	5	7	13	5	7	13	5	10	18	5	10	18
Signal 0-10V	%			44	68	90	44	68	90	52	70	90	52	70	90	49	68	90	49	68	90
<b>Fan coil sound data (4)</b>																					
Sound power level	dB(A)			35,0	46,0	51,0	35,0	46,0	51,0	34,0	41,0	48,0	34,0	41,0	48,0	37,0	44,0	51,0	37,0	44,0	51,0
Sound pressure	dB(A)			27,0	38,0	43,0	27,0	38,0	43,0	26,0	33,0	40,0	26,0	33,0	40,0	29,0	36,0	43,0	29,0	36,0	43,0
<b>Water coil</b>																					
Water content main coil	l			0,5			0,7			0,8			1,0			1,0			1,4		
<b>Diametre hydraulic fittings</b>																					
Main coil	Ø			1/2"			1/2"			3/4"			3/4"			3/4"			3/4"		
	FCZI500P			FCZI550P			FCZI700P			FCZI750P			FCZI900P			FCZI950P					
	1	2	3	1	2	3	1	2	3	1	2	3	1	2	3	1	2	3			
	L	M	H	L	M	H	L	M	H	L	M	H	L	M	H	L	M	H			
<b>Heating performance 70 °C / 60 °C (1)</b>																					
Heating capacity	kW			5,27	7,31	8,50	5,82	8,34	9,75	8,10	9,80	11,00	9,10	11,30	12,50	10,77	13,35	15,14	11,20	14,42	17,10
Water flow rate system side	l/h			462	641	745	510	731	855	710	860	964	798	991	1096	945	1171	1328	982	1264	1500
Pressure drop system side	kPa			12	21	28	10	20	26	17	24	29	10	15	18	12	17	22	16	24	33
<b>Heating performance 45 °C / 40 °C (2)</b>																					
Heating capacity	kW			2,62	3,63	4,22	2,89	4,14	4,85	4,03	4,87	5,47	4,52	5,62	6,21	5,35	6,64	7,53	5,57	7,17	8,50
Water flow rate system side	l/h			455	631	734	502	720	842	699	846	950	786	975	1079	930	1152	1307	967	1245	1476
Pressure drop system side	kPa			12	21	28	10	20	26	16	24	29	10	14	18	12	17	22	15	24	33
<b>Cooling performance 7 °C / 12 °C (3)</b>																					
Cooling capacity	kW			2,68	3,69	4,25	2,91	4,13	4,79	3,92	4,89	5,50	4,27	5,34	6,14	4,29	5,00	6,91	5,77	7,32	8,60
Sensible cooling capacity	kW			1,94	2,73	3,18	2,07	2,98	3,49	2,99	3,76	4,30	3,20	4,05	4,72	2,97	3,78	5,68	3,80	4,87	5,78
Water flow rate system side	l/h			460	634	731	501	711	824	675	841	946	734	918	1056	738	860	1189	992	1259	1479
Pressure drop system side	kPa			13	22	29	12	22	28	16	24	30	10	14	18	10	12	22	15	22	30
<b>Fan</b>																					
Type	type			Centrifugal																	
Fan motor	type			Inverter																	
Number	no.			2			2			3			3			3			3		
Air flow rate	m <sup>3</sup> /h			400	600	720	400	600	720	700	930	1140	700	930	1140	700	930	1140	700	930	1140
Input power	W			7	18	31	4	10	19	30	40	80	30	40	80	30	40	80	30	40	80
Signal 0-10V	%			50	74	90	50	74	90	56	72	90	56	72	90	56	72	90	56	72	90
<b>Fan coil sound data (4)</b>																					
Sound power level	dB(A)			42,0	51,0	56,0	42,0	51,0	56,0	50,0	57,0	62,0	50,0	57,0	62,0	51,0	57,0	62,0	51,0	57,0	62,0
Sound pressure	dB(A)			34,0	43,0	48,0	34,0	43,0	48,0	42,0	49,0	54,0	42,0	49,0	54,0	43,0	49,0	54,0	43,0	49,0	54,0
<b>Water coil</b>																					
Water content main coil	l			1,0			1,4			1,2			1,6			1,8			2,3		
<b>Diametre hydraulic fittings</b>																					
Main coil	Ø			3/4"																	

(1) Room air temperature 20 °C d.b.; Water (in/out) 70 °C/60 °C

(2) Room air temperature 20 °C d.b.; Water (in/out) 45 °C/40 °C; EUROVENT

(3) Room air temperature 27 °C d.b./19 °C w.b.; Water (in/out) 7 °C/12 °C; EUROVENT

(4) Aermec determines the sound power value on the basis of measurements taken in accordance with standard UNI EN 16583:15, respecting the Eurovent certification.

4-pipe

	FCZI201P			FCZI301P			FCZI401P			FCZI501P			FCZI701P			FCZI901P			
	1	2	3	1	2	3	1	2	3	1	2	3	1	2	3	1	2	3	
	L	M	H	L	M	H	L	M	H	L	M	H	L	M	H	L	M	H	
<b>Heating performance 65 °C / 55 °C (1)</b>																			
Heating capacity	kW	1,02	1,35	1,60	1,80	2,18	2,56	2,21	2,65	3,12	2,59	3,34	3,73	3,66	4,29	4,94	4,73	5,63	5,72
Water flow rate system side	l/h	89	118	140	158	191	224	186	232	273	227	293	327	320	375	437	414	492	501
Pressure drop system side	kPa	4	8	10	16	23	30	4	6	8	6	8	10	11	14	18	8	12	12
<b>Cooling performance 7 °C / 12 °C (2)</b>																			
Cooling capacity	kW	0,89	1,28	1,60	1,68	2,17	2,65	2,20	2,92	3,60	2,68	3,69	4,25	3,92	4,89	5,50	4,29	5,00	6,91
Sensible cooling capacity	kW	0,71	1,05	1,33	1,26	1,65	2,04	1,59	2,14	2,67	1,94	2,73	3,18	2,99	3,76	4,30	2,97	3,78	5,68
Water flow rate system side	l/h	153	221	275	288	374	456	379	503	619	460	634	731	675	841	946	738	860	1189
Pressure drop system side	kPa	6	12	18	8	13	18	10	16	24	13	22	29	16	24	30	10	12	22
<b>Fan</b>																			
Type	type	Centrifugal																	
Fan motor	type	Inverter																	
Number	no.	1			2			2			2			3			3		
Air flow rate	m <sup>3</sup> /h	140	220	290	260	350	450	330	460	600	400	600	720	700	930	1140	700	930	1140
Input power	W	7	8	14	5	7	13	5	10	18	7	16	31	30	40	80	30	40	80
Signal 0-10V	%	44	68	90	52	70	90	49	68	90	50	74	90	56	72	90	56	72	90
<b>Fan coil sound data (3)</b>																			
Sound power level	dB(A)	35,0	46,0	51,0	34,0	41,0	48,0	37,0	44,0	51,0	42,0	51,0	56,0	50,0	57,0	62,0	51,0	57,0	62,0
Sound pressure	dB(A)	27,0	38,0	43,0	26,0	33,0	40,0	29,0	36,0	43,0	34,0	43,0	48,0	42,0	49,0	54,0	43,0	49,0	54,0
<b>Water coil</b>																			
Water content main coil	l	0,5			0,8			1,0			1,0			1,2			1,8		
Water content the secondary coil	l	0,2			0,3			0,3			0,3			0,4			0,7		
<b>Diameter hydraulic fittings</b>																			
Main coil	∅	1/2"			3/4"			3/4"			3/4"			3/4"			3/4"		
Secondary coil	∅	1/2"																	

(1) Room air temperature 20°C d.b.; Water (in/out) 65 °C/55 °C; EUROVENT

(2) Room air temperature 27°C d.b./19°C w.b.; Water (in/out) 7 °C/12 °C; EUROVENT

(3) Aermec determines the sound power value on the basis of measurements taken in accordance with standard UNI EN 16583:15, respecting the Eurovent certification.



**PERFORMANCE DATA FOR UNITS WITH HEAD (EUROVENT CERTIFICATE FCP-H)**

**2-pipe**

	FCZI200P			FCZI250P			FCZI300P			FCZI350P			FCZI400P			FCZI450P			FCZI500P			FCZI550P		
	1	2	3	1	2	3	1	2	3	1	2	3	1	2	3	1	2	3	1	2	3	1	2	3
	L	M	H	L	M	H	L	M	H	L	M	H	L	M	H	L	M	H	L	M	H	L	M	H

**Heating performance 70 °C / 60 °C (1)**

Heating capacity	kW	1,81	3,16	3,34	2,01	3,40	3,62	3,08	4,83	5,23	3,32	5,43	5,83	3,96	5,85	6,34	4,10	6,44	6,96	5,39	7,28	7,63	5,92	8,37	8,71
Water flow rate system side	l/h	156	272	287	173	292	311	265	415	450	285	467	502	341	503	545	353	554	599	464	626	656	509	720	749
Pressure drop system side	kPa	6	13	16	7	17	19	7	14	16	7	17	19	9	17	19	5	12	13	12	22	23	11	20	21

**Heating performance 45 °C / 40 °C (2)**

Heating capacity	kW	0,90	1,57	1,66	1,00	1,69	1,80	1,53	2,40	2,60	1,65	2,70	2,90	1,97	2,91	3,15	2,04	3,20	3,46	2,68	3,62	3,79	2,94	4,16	4,33
Water flow rate system side	l/h	155	270	288	172	291	308	263	413	447	284	464	499	339	501	542	351	550	595	461	623	652	506	715	745
Pressure drop system side	kPa	6	13	16	7	17	19	7	14	16	7	17	19	9	17	19	5	12	13	12	22	23	11	20	21

**Cooling performance 7 °C / 12 °C (3)**

Cooling capacity	kW	0,80	1,37	1,45	0,95	1,67	1,76	1,40	2,38	2,53	1,66	2,70	2,88	2,03	2,98	3,21	2,22	3,28	3,55	2,73	3,68	3,84	2,97	4,15	4,31
Sensible cooling capacity	kW	0,63	1,13	1,20	0,70	1,29	1,37	1,10	1,82	1,94	1,15	1,94	2,07	1,45	2,18	2,36	1,54	2,35	2,56	1,98	2,73	2,85	2,11	2,98	3,12
Water flow rate system side	l/h	138	236	249	163	287	303	241	409	435	285	464	495	349	512	552	382	564	610	469	633	660	511	714	741
Pressure drop system side	kPa	5	13	16	8	17	19	7	14	16	9	17	19	9	17	19	8	12	13	13	22	23	12	20	21

**Fan**

Type	type	Centrifugal																							
Fan motor	type	Inverter																							
Number	no.	1			1			2			2			2			2			2			2		
Air flow rate	m³/h	123	240	257	123	240	257	225	390	424	225	390	424	300	470	515	300	470	515	410	600	630	410	600	630
High static pressure	Pa	13	50	57	13	50	57	16	50	59	16	50	53	20	50	60	20	50	56	23	50	55	23	50	55
Input power	W	7	27	31	7	27	31	10	11	40	10	30	40	14	38	48	14	38	48	18	50	60	18	50	60
Signal 0-10V	%	43	84	90	43	84	90	48	83	90	48	83	90	52	82	90	52	82	90	58	85	90	58	85	90

**Duct type fan coil sound data (4)**

Sound power level (inlet + radiated)	dB(A)	37,0	57,0	59,0	37,0	57,0	59,0	36,0	50,0	53,0	36,0	50,0	53,0	43,0	53,0	55,0	43,0	53,0	55,0	45,0	56,0	57,0	45,0	56,0	57,0
Sound power level (outlet)	dB(A)	33,0	53,0	55,0	33,0	53,0	55,0	32,0	47,0	49,0	32,0	47,0	49,0	39,0	49,0	52,0	39,0	49,0	52,0	42,0	52,0	52,0	42,0	52,0	52,0

**Water coil**

Water content main coil	l	0,5			0,7			0,8			1,0			1,0			1,4			1,0			1,4		
-------------------------	---	-----	--	--	-----	--	--	-----	--	--	-----	--	--	-----	--	--	-----	--	--	-----	--	--	-----	--	--

**Diameter hydraulic fittings**

Main coil	∅	1/2"			1/2"			3/4"			3/4"			3/4"			3/4"			3/4"			3/4"		
-----------	---	------	--	--	------	--	--	------	--	--	------	--	--	------	--	--	------	--	--	------	--	--	------	--	--

	FCZI700P			FCZI750P			FCZI900P			FCZI950P		
	1	2	3	1	2	3	1	2	3	1	2	3
	L	M	H	L	M	H	L	M	H	L	M	H

**Heating performance 70 °C / 60 °C (1)**

Heating capacity	kW	5,33	8,34	8,88	6,17	9,52	10,15	6,58	11,15	11,87	6,68	11,63	12,66
Water flow rate system side	l/h	468	732	779	541	835	890	566	958	1021	574	1000	1088
Pressure drop system side	kPa	8	17	20	5	11	12	5	13	14	6	17	19

**Heating performance 45 °C / 40 °C (2)**

Heating capacity	kW	2,67	4,15	4,40	2,46	4,69	5,00	3,27	5,54	5,90	3,32	5,78	6,29
Water flow rate system side	l/h	460	720	767	418	806	860	562	953	1015	571	994	1082
Pressure drop system side	kPa	8	18	20	3	11	12	5	13	14	6	17	19

**Cooling performance 7 °C / 12 °C (3)**

Cooling capacity	kW	2,20	4,00	4,30	2,60	4,41	4,70	2,81	4,80	5,20	3,58	6,00	6,46
Sensible cooling capacity	kW	1,71	3,00	3,20	1,90	3,30	3,50	2,10	3,60	3,90	2,33	3,94	4,27
Water flow rate system side	l/h	378	688	739	447	760	818	483	825	894	616	1032	1111
Pressure drop system side	kPa	7	18	20	4	11	12	5	13	14	7	17	19

**Fan**

Type	type	Centrifugal																							
Fan motor	type	Inverter																							
Number	no.	3			3			3			3														
Air flow rate	m³/h	405	730	799	405	730	799	405	730	799	405	730	799												
High static pressure	Pa	15	50	60	15	50	60	15	50	60	15	50	60												
Input power	W	21	61	78	21	61	78	21	61	78	21	61	78												
Signal 0-10V	%	46	82	90	46	82	90	45	84	90	45	84	90												

**Duct type fan coil sound data (4)**

Sound power level (inlet + radiated)	dB(A)	38,0	55,0	58,0	38,0	55,0	58,0	44,0	55,0	58,0	44,0	55,0	58,0
Sound power level (outlet)	dB(A)	34,0	51,0	54,0	34,0	51,0	54,0	40,0	51,0	54,0	40,0	51,0	54,0

**Water coil**

Water content main coil	l	1,2			1,6			1,8			2,3		
-------------------------	---	-----	--	--	-----	--	--	-----	--	--	-----	--	--

**Diameter hydraulic fittings**

Main coil	∅	3/4"											
-----------	---	------	--	--	--	--	--	--	--	--	--	--	--

(1) Room air temperature 20 °C d.b.; Water (in/out) 70 °C/60 °C

(2) Room air temperature 20 °C d.b.; Water (in/out) 45 °C/40 °C; EUROVENT

(3) Room air temperature 27 °C d.b./19 °C w.b.; Water (in/out) 7 °C/12 °C; EUROVENT

(4) Aermec determines the sound power value on the basis of measurements taken in accordance with standard UNI EN 16583:15, respecting the Eurovent certification.

4-pipe

		FCZI201P			FCZI301P			FCZI401P			FCZI501P			FCZI701P			FCZI901P		
		1	2	3	1	2	3	1	2	3	1	2	3	1	2	3	1	2	3
		L	M	H	L	M	H	L	M	H	L	M	H	L	M	H	L	M	H
<b>Heating performance 65 °C / 55 °C (1)</b>																			
Heating capacity	kW	0,94	1,42	1,49	1,60	2,34	2,47	1,99	2,69	2,85	2,62	3,59	3,45	2,99	3,70	3,92	3,17	5,09	5,47
Water flow rate system side	l/h	81	122	128	138	201	212	171	231	245	225	309	297	257	318	337	273	438	470
Pressure drop system side	kPa	4	9	9	6	12	13	4	7	8	6	9	9	8	12	13	4	10	11
<b>Cooling performance 7 °C / 12 °C (2)</b>																			
Cooling capacity	kW	0,80	1,37	1,45	1,40	2,38	2,53	2,03	2,98	3,21	2,73	3,68	3,84	2,20	4,00	4,30	2,80	4,80	5,24
Sensible cooling capacity	kW	0,63	1,13	1,20	1,10	1,82	1,94	1,45	2,18	2,36	1,98	2,73	2,85	1,71	3,00	3,20	2,10	3,60	3,90
Water flow rate system side	l/h	138	236	249	241	409	435	349	512	552	469	633	660	378	688	739	482	825	901
Pressure drop system side	kPa	5	14	16	7	15	17	9	13	20	13	23	25	6	18	20	5	12	13
<b>Fan</b>																			
Type	type	Centrifugal																	
Fan motor	type	Inverter																	
Number	no.	1			2			2			2			3			3		
Air flow rate	m <sup>3</sup> /h	123	240	257	225	390	424	300	470	515	410	600	630	405	730	799	405	730	799
High static pressure	Pa	13	50	57	16	50	59	20	50	60	23	50	55	15	50	60	15	50	60
Input power	W	7	27	31	10	31	40	14	38	58	18	50	60	21	61	78	21	61	78
Signal 0-10V	%	43	84	90	48	83	90	52	82	90	58	85	90	46	82	90	45	84	90
<b>Duct type fan coil sound data (3)</b>																			
Sound power level (inlet + radiated)	dB(A)	37,0	57,0	59,0	36,0	50,0	53,0	43,0	53,0	55,0	45,0	56,0	57,0	38,0	55,0	58,0	38,0	55,0	58,0
Sound power level (outlet)	dB(A)	33,0	53,0	55,0	32,0	47,0	49,0	39,0	49,0	52,0	42,0	52,0	52,0	34,0	51,0	54,0	34,0	51,0	54,0
<b>Water coil</b>																			
Water content main coil	l	0,5			0,8			1,0			1,0			1,2			1,8		
Water content the secondary coil	l	0,2			0,3			0,3			0,3			0,4			0,7		
<b>Diametre hydraulic fittings</b>																			
Main coil	∅	1/2"			3/4"			3/4"			3/4"			3/4"			3/4"		
Secondary coil	∅	1/2"																	

(1) Room air temperature 20°C d.b.; Water (in/out) 65 °C/55 °C; EUROVENT

(2) Room air temperature 27°C d.b./19°C w.b.; Water (in/out) 7 °C/12 °C; EUROVENT

(3) Aermec determines the sound power value on the basis of measurements taken in accordance with standard UNI EN 16583:15, respecting the Eurovent certification.

## DIMENSIONS

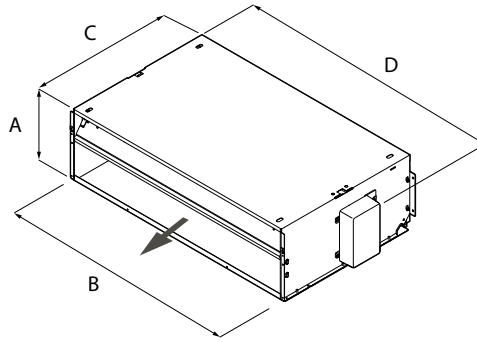

		FCZI200P	FCZI250P	FCZI300P	FCZI350P	FCZI400P	FCZI450P
<b>Dimensions and weights</b>							
A	mm	216	216	216	216	216	216
B	mm	522	522	753	753	973	973
C	mm	453	453	453	453	453	453
D	mm	562	562	793	793	1013	1013
Net weight	kg	12	14	14	16	20	22
		FCZI500P	FCZI550P	FCZI700P	FCZI750P	FCZI900P	FCZI950P
<b>Dimensions and weights</b>							
A	mm	216	216	216	216	216	216
B	mm	973	973	1122	1122	1122	1122
C	mm	453	453	453	453	558	558
D	mm	1013	1013	1147	1147	1147	1147
Net weight	kg	23	24	29	31	32	32
		FCZI201P	FCZI202P	FCZI301P	FCZI302P	FCZI401P	FCZI402P
<b>Dimensions and weights</b>							
A	mm	216	216	216	216	216	216
B	mm	522	522	753	753	973	973
C	mm	453	453	453	453	453	453
D	mm	562	562	793	793	1013	1013
Net weight	kg	13	14	15	16	21	22
		FCZI501P	FCZI502P	FCZI701P	FCZI702P	FCZI901P	FCZI902P
<b>Dimensions and weights</b>							
A	mm	216	216	216	216	216	216
B	mm	973	973	1122	1122	1122	1122
C	mm	453	453	453	453	558	558
D	mm	1013	1013	1147	1147	1147	1147
Net weight	kg	23	24	30	31	32	32

Aermec reserves the right to make any modifications deemed necessary.  
All data is subject to change without notice. Aermec does not assume responsibility or liability for errors or omissions.

**Aermec S.p.A.**  
Via Roma, 996 - 37040 Bevilacqua (VR) - Italia  
Tel. 0442633111 - Telefax 044293577  
www.aermec.com