



REGOLAZIONE ELETTRONICA • ELECTRONIC REGULATION • REGLAGE ELECTRONIQUE
ELEKTRISCHE REGELVORRICHTUNG • REGULACIÓN ELÉCTRICA

MANUALE USO • USAGE MANUAL • MANUEL D'UTILISATION
BEDIENUNGSANLEITUNG • MANUAL DE INSTRUCCIONES

MODUCONTROL



IT
pag 3

EN
pag 38

FR
pag 73

DE
pag 108

ES
pag 143



Characteristics of the regulation

The command panel of the unit allows the rapid setting of the working parameters of the machine, and their visualisation. The display consists of 4 figures and various LEDs for indicating the type of operational mode, the visualisation of the parameters set and of any alarms triggered. The card stores all the default settings and any modifications. With the installation of the PR3 remote panel accessory, it is possible to control the switching on and off from a distance, as well as the setting of the operational mode (cooling-heating), and the visualisation of the alarm summary.



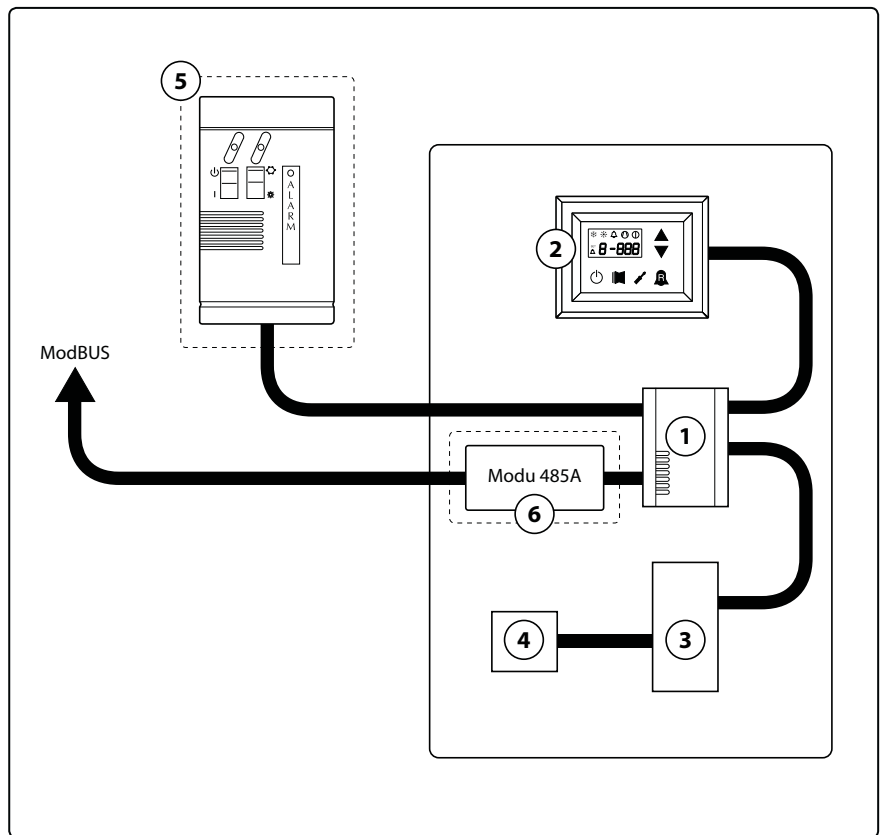













Modu_485A adding the accessory, the unit can be managed in a VMF, or be managed via a BMS via Modbus protocol. After the absence of voltage for any period of time, the unit is able to start up again automatically, maintaining the original settings.







Index	Element	Notes
1	Moducontrol Board	
2	Command interface on the machine	
3	Board for probes, valves and communication management with inverter module	Present on ANLI units only
4	Board for inverter compressor management	Present on ANLI units only
5	Simplified remote panel	Accessory PR3
6	ModBus protocol interface board	Modu_485A accessory

ATTENTION: If you wish to implement a BMS management system, a manual is available on our site www.aermec.com with all specifications necessary for the realisation of a serial supervision system.

USER MENU default settings

Present on the units																
String parameter	StA	StF	bnF	StC	bnC	CSt	SF1	tF1	SF2	tF2	SC1	tC1	SC2	tC2	SAS	bAS
Index parameter	0	1	2	3	4	5	6	7	8	9	A	B	C	D	E	F

Unit	ANL	0	7	5	45	5	0	12	18	7	30	45	0	35	18	50	10
	ANLI	0	7	5	45	5	0	12	18	7	30	45	0	35	18	50	10
	ANR	0	7	5	45	5	0	12	18	7	30	45	0	35	18	50	10
	ANF	0	7	5	45	5	0	12	18	7	30	45	0	35	18	50	10
	ANK	0	7	5	45	5	0	12	18	7	30	45	0	35	18	50	10
	SRPV1	1	---	---	65	5	0	12	18	7	30	45	0	35	18	50	10
	SRA	1	---	---	65	5	0	12	18	7	30	45	0	35	18	50	10
	WRL	---	7	5	---	---	0	12	18	7	30	---	---	---	---	---	---

	Unit able to produce hot water (heat pump water or heating only unit)
	Unit able to produce cold water (reversible heat pump water or cooling only unit)
	All units (heat pumps, heating only or cooling only)
	Unit that can produce domestic hot water

Functions relative to USER parameters			
Index String	Function	Index String	Function
0 - StA	Operating mode selection	8 - SF2	Set at cooling 2
1 - StF	Set at cooling	9 - tF2	Outdoor air temperature (cooling)
2 - bnF	Cooling band	A - SC1	Set at heating 1
3 - StC	Set at heating	B - tC1	Outdoor air temperature 1 (heating)
4 - bnC	Heating band	C - SC2	Set at heating 2
5 - CSt	Correction set	D - tC2	Outdoor air temperature 2 (heating)
6 - SF1	Set at cooling 1	E - SAS	DHW Set
7 - tF1	Outdoor air temperature 1	F - bAS	DHW Band

User interface and parameter visualisations

The main user interface is represented by a LED panel with capacitive keyboard (touch keys); the visualisations are arranged in three menus:

• **READINGS menu (key (C) Fig.1)**

Containing the information (visualisation mode only) relating to current unit functioning.

• **SETTINGS menu (key (D) Fig.1)**

Containing all the parameters that the user can modify according to system requirements; these parameters are grouped together in various sub-menus:

- **USER menu (Password 000);**
- **INSTALLER menu (Password 030);**
- **ELECTRIC HEATER menu (Password 001);**

• **ALARM log (key (E) Fig.1)**

The alarm log records unit error and/or malfunctioning conditions (whether alarms or pre-alarms).

During normal functioning, the monitor visualises the last parameter modified; if no other keys are pressed for at least 5 minutes, the monitor activates the screensaver mode (this function can be set via the parameter (i) in the **INSTALLER menu**).

To display parameters and/or readings, 4 figures are used; the first is the indicator i.e. a number allowing the user to know which parameter or reading he is visualising (Fig.3).

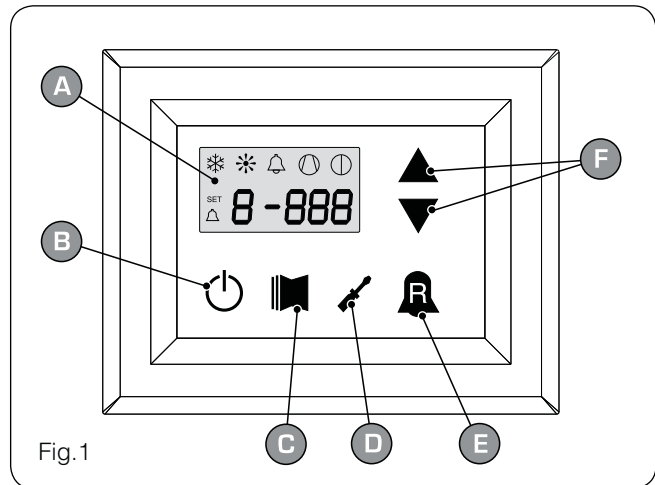

Fig.1

User interface (Fig.1)	
A	Monitor visualisation
B	“ON” key
C	Key to access readings menu
D	Button key to access set menu
E	Button key to access alarm record
F	Keys to scroll/increase-decrease parameters

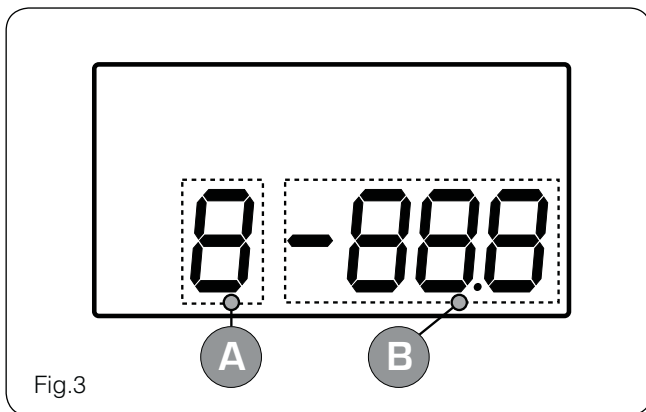

Fig.3

User interface (Fig.3)	
A	Parameter index
B	Parameter abbreviation / Parameter value

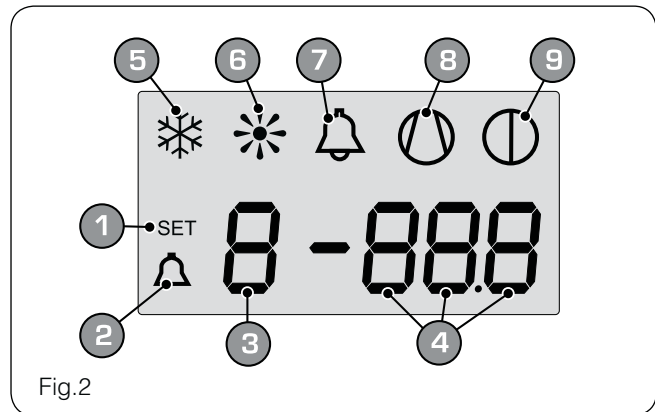

Fig.2

Monitor visualisation (Fig.2)	
1	SETTINGS menu currently visualised
2	ALARMS menu currently visualised
3	Parameter index
4	Parameter abbreviation / Parameter value
5	Season indicator SUMMER
6	Season indicator WINTER
7	Indicator of current alarm status
8	Indicator of current compressor operational mode (this indication can have different flashing frequencies).
9	Indicator of stop in progress

Readings menu

To access the readings menu, press the key in (Fig.4); once the readings menu has been accessed, the monitor will display the readings index and a 3-character string that identifies it; the string will be displayed for one second, after which it is replaced by the value of the

reading itself. To move on to the next reading, press the key in (Fig.5); to go back to the previous one, press the key in (Fig.6). Every time you pass from one reading to another, apart from the change in the index value you will also see (for one second) the string identifying

the current reading (it is possible, however, to identify any reading via the value of the indicator, comparing it with the table below).

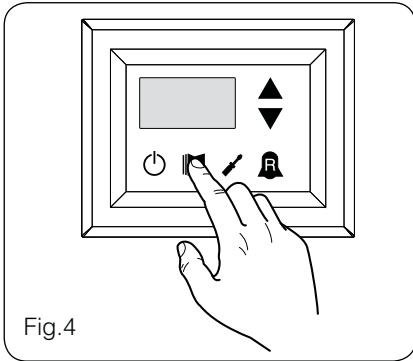

Fig.4

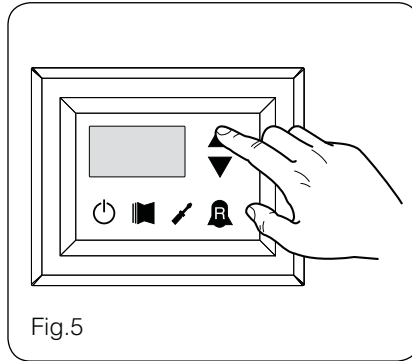

Fig.5

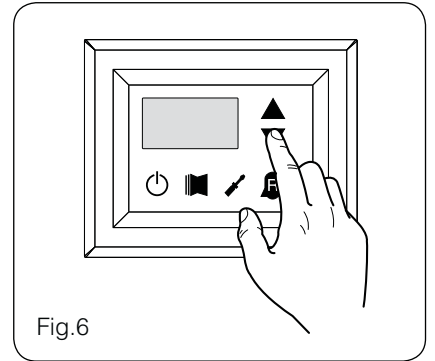

Fig.6

Index - String	Meaning of the reading
0 t u A	Water output temperature
1 t i A	Water input temperature
2 t S b	Coil temperature
3 t G P	Force gas temperature
4 t A E	Outside air temperature
5 A P	Delivery pressure
6 b P	Suction pressure
7 t E r	Thermostat
8 S A b	Safety band on force-off
9 C P	CP times
A H C O	Hours of operation (thousands)
b H C O	Hours of operation (units)
C S P O	Compressor pickup current (thousands)

Index - String	Meaning of the reading
d S P O	Compressor pickup current (units)
E r E L	Software release
F b L d	Minor software releases
G S E t	Setting currently in use
H d C P	DCP pressure setting
, d C P	DCP pressure differential
J H C I	Operating hours COMPRESSOR 2 (thousands)
L H C I	Operating hours COMPRESSOR 2 (units)
n S P I	Compressor pickup current COMPRESSOR 2 (thousands)
o S P I	Compressor pickup current COMPRESSOR 2 (units)
P P o	Power fraction
q r F q	Required frequency (INVERTER)
r P r F	Pressure drop

	Parameter visible on ALL the units
	Parameter ONLY visible on units suitable for production of hot water

	Parameter ONLY visible on units with condensation control device on board
	Parameter ONLY visible on units fitted with twin compressor
	Parameter ONLY visible on units fitted with inverter compressor

ADVANCED READINGS menu

To enter the ADVANCED READINGS menu, press the key shown in (Fig.7). Once the key has been pressed the password must be inserted for access to the various menus. To access the user menu the **password is 010**. To modify

the value of the password use the arrow keys. Once the correct password has been inserted, press the key shown in (Fig.7). The display shows the index of the reading and a string of three characters that identify it. The string remains

displayed for one second, after which it is replaced by the value relative to the reading itself. To pass to the next reading, use the arrow keys (Fig.8).



PASSWORD = 010

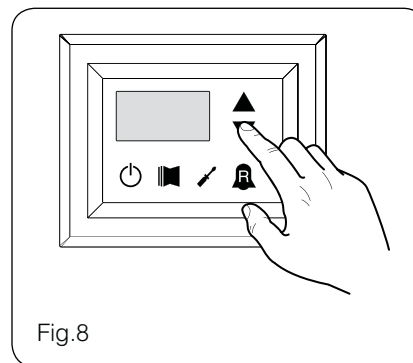
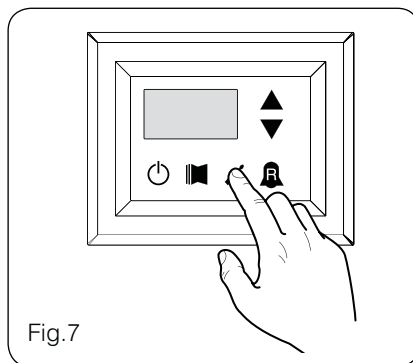

Index - String	Reading Meaning	Notes
0 Cor	Inverter Current	Current (in Amperes) measured by the inverter module; Parameter displayed with ANLI 21, 26, 40, 45, 71, 75, 80,100 only;
1 Uo	Inverter output voltage	Output voltage (in Volt) measured by the inverter module; Parameter displayed with ANLI21, 26, 40, 45, 71, 75, 80,100 only;
2 Uob	BUS voltage	BUS voltage (in Volt) measured by the inverter module; Parameter displayed with ANLI21, 26, 40, 45, 71, 75, 80,100 only;
3 HSt	Inverter dissipater temperature	Temperature (in C°) of the inverter module heat dissipater; Parameter displayed with ANL21, 26, 40, 45, 71, 75, 80,100 inverter only;
4 dFo	Value of the dynamic OFF force	Current dynamic ForceOff value calculated on the basis of the outdoor air temperature
5 dHt	DHW remote probe value	Value read by the remote probe positioned in the plant water storage tank; function enabled by the parameter (0) in the INSTALLER menu
6 ASP	Compressor intake probe value	Temperature read from the robe positioned on compressor intake. Parameter displayed only with ANLI 21, 26, 40, 45, 71, 75, 80;

USER menu

To access the USER menu, press the key in (Fig.7). Once the key has been pressed, you must insert the password to access the various menus; to access the user menu, the **password is 000** (displayed by default). To modify the value of the passwords, use the arrow keys. When you have inserted the correct

password, press the key in (Fig.7). The monitor will show the index of the USER parameter and a 3-character string that identifies it; the string will be displayed for one second, after which it is replaced by the value of the parameter itself. To move on to the next parameter, use the arrow keys (Fig.8). To modify a pa-

rameter, just select it, press the key in (Fig.7), modify the assigned value using the arrow keys in (Fig.8), and confirm the modification by pressing the key in (Fig.7) again.



PASSWORD = 000

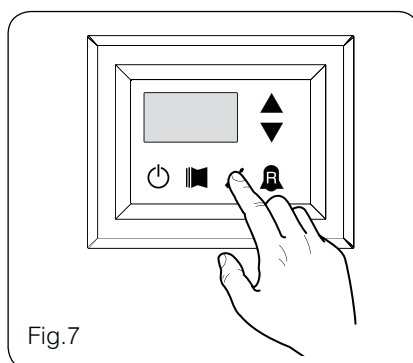

Fig.7

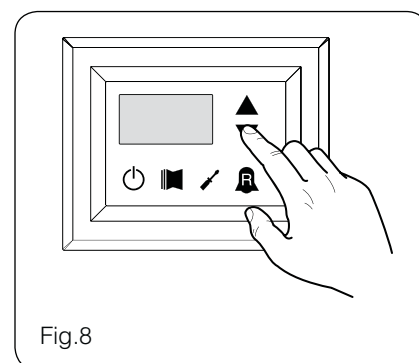



Fig.8

Setting operational parameters (user level)

Setting of operational mode (HOT/COLD)

Index - String	MIN value	MAX value	Parameter function
0 S _{EA} 	0	1	This parameter identifies the functioning mode set for the unit: <ul style="list-style-type: none"> • set value = 0 - Cooling mode; • set value = 1 - Heating mode. In cooling only units, this parameter is displayed but it cannot be modified. In software versions prior to 3.75, to make the season change the unit must be in standby.

Setting of cooling temperature

Index - String	MIN value	MAX value	Parameter function
1 S _{LF}	-20 °C	26 °C	This parameter indicates the value of the work setting active in cooling mode.



Parameter visible ONLY on units suitable for the production of hot water



Parameter visible ONLY on units suitable for the production of DHW



Parameter visible ONLY on units with condensation control device on board





Parameter ONLY visible on units fitted with twin compressor





Parameter ONLY visible on units fitted with inverter compressor

Setting of proportional cooling band			
Index - String	MIN value	MAX value	Parameter function
2 bnf	1 °C	20 °C	This parameter indicates the proportional band applied to the cooling set; this band produces the optimised management of the compressor, only switching it on if the inlet/outlet water temperature (depending on the type of control set by parameter (0) in the installer menu) is greater than the cooling work set (parameter (1) user menu) plus the value of this parameter.

Setting heating mode temperature set			
Index - string	Value MIN	Value MAX	Parameter function
3 StC 	25 °C	(*)	This parameter indicates the active work set value in the heating mode. This parameter is displayed in the cooling only units but cannot be modified. (*): - the maximum limit can be configured via the parameter (t) of the installer menu; - if the parameter (8) of the installer menu is set at 4, the maximum limit becomes 70°C in order to allow insertion of a set-point for boiler adjustment;

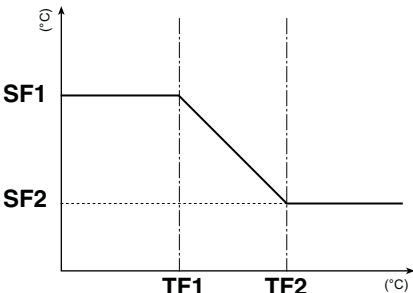
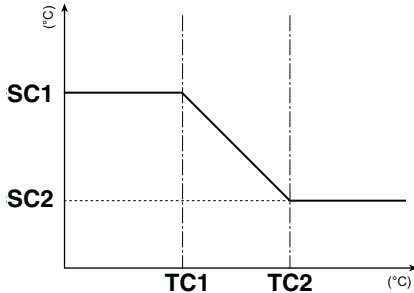
Setting of proportional heating band			
Index - String	MIN value	MAX value	Parameter function
4 bnC 	1 °C	20 °C	This parameter indicates the proportional band applied to the heating set; this band produces the optimised management of the compressor, only switching it on if the inlet/outlet water temperature (depending on the type of control set by parameter (0) in the installer menu) is less than the heating work set (parameter (3) user menu), minus the value of this parameter. In cooling only units, this parameter is displayed but it cannot be modified.

Settings made on the basis of outside temperature			
Index - String	MIN value	MAX value	Parameter function
5 CSt	0	3	<p>This setting activates the algorithm of compensation of the work setting:</p> <div style="display: flex; justify-content: space-around;"> <div style="text-align: center;">  <p>SF1 SF2</p> <p>TF1 TF2 (°C)</p> <p>SF1: index (6) user menu; SF2: index (8) user menu; TF1: index (7) user menu; TF2: index (9) user menu;</p> <p>In cooling mode, the work setting is calculated automatically on the basis of the outside temperature, following the logic highlighted in the diagram.</p> </div> <div style="text-align: center;">  <p>SC1 SC2</p> <p>TC1 TC2 (°C)</p> <p>SC1: index (A) user menu; SC2: index (C) user menu; TC1: index (B) user menu; TC2: index (d) user menu;</p> <p>In heating mode, the work setting is calculated automatically on the basis of the outside temperature, following the logic highlighted in the diagram.</p> </div> </div>

 Parameter visible ONLY on units suitable for the production of hot water

 Parameter visible ONLY on units suitable for the production of DHW

 Parameter visible ONLY on units with condensation control device on board

 Parameter ONLY visible on units fitted with twin compressor

 Parameter ONLY visible on units fitted with inverter compressor

Setting cooling temperature setpoint 1			
Index - String	MIN value	MAX value	Parameter function
6 SF1	-20 °C	26 °C	This parameter indicates the maximum value of the cooling setting, corresponding with the minimum outside air temperature (index (7) user menu). This parameter is only visible if the compensation function has been activated (index (5) user menu).

Setting the outside air temperature 1			
Index - String	MIN value	MAX value	Parameter function
7 tF1	-40 °C	50 °C	This parameter indicates the minimum outside air temperature taken into consideration for cooling compensation. This parameter is only visible if the compensation function has been activated (index (5) user menu).

Setting cooling temperature setpoint 2			
Index - String	MIN value	MAX value	Parameter function
8 SF2	-20 °C	26 °C	This parameter indicates the minimum value of the cooling setting, corresponding with the maximum outside air temperature (index (9) user menu). This parameter is only visible if the compensation function has been activated (index (5) user menu).

Setting the outside air temperature 2			
Index - String	MIN value	MAX value	Parameter function
9 tF2	-40 °C	50 °C	This parameter indicates the maximum outside air temperature taken into consideration for cooling compensation. This parameter is only visible if the compensation function has been activated (index (5) user menu).

Setting heating set 1			
Index - string	Value MIN	Value MAX	Parameter function
A SC1 	25 °C	(*)	This parameter indicates the maximum value set at heating, in correspondence with the minimum outdoor air temperature (user menu index (b) This parameter is visible only if the compensation function is activated (use menu index (5)). (*): - the maximum limit can be configured via the parameter (t) of the installer menu; - if the parameter (8) of the installer menu is set at 4, the maximum limit becomes 70°C in order to allow insertion of a set-point for boiler adjustment;

Setting the outside air temperature 1 (heating)			
Index - String	MIN value	MAX value	Parameter function
b tC1 	-40 °C	50 °C	This parameter indicates the minimum outside air temperature taken into consideration for heating compensation. This parameter is only visible if the compensation function has been activated (index (5) user menu).



Parameter visible ONLY on units suitable for the production of hot water



Parameter visible ONLY on units suitable for the production of DHW



Parameter visible ONLY on units with condensation control device on board





Parameter ONLY visible on units fitted with twin compressor





Parameter ONLY visible on units fitted with inverter compressor

Setting heating set 2			
Index - string	Value MIN	Value MAX	Parameter function
 C 5C2	25 °C	(*)	This parameter indicates the minimum value set at heating, in correspondence with the maximum outdoor air temperature (user menu index (c) This parameter is visible only if the compensation function is activated (use menu index (5)). (*): - the maximum limit can be configured via the parameter (t) of the installer menu; - if the parameter (8) of the installer menu is set at 4, the maximum limit becomes 70°C in order to allow insertion of a set-point for boiler adjustment;

Setting the outside air temperature 2 (heating)			
Index - String	MIN value	MAX value	Parameter function
 d tC2	-40 °C	50 °C	This parameter indicates the maximum outside air temperature taken into consideration for heating compensation. This parameter is only visible if the compensation function has been activated [index (5) user menu].

Setting DHW set			
Index - string	Value MIN	Value MAX	Parameter function
 E SAS	25 °C	(*)	The heat pumps have a work set for the production of DHW; this set indicates the produced water temperature above which the compressor is stopped. Remember that to display this set, the parameter (A) of the installer menu must be active (value set = 1). (*): - the maximum limit can be configured via the parameter (t) of the installer menu; - if the parameter (8) of the installer menu is set at 4, the maximum limit becomes 70°C in order to allow insertion of a set-point for boiler adjustment;

Setting domestic water proportional band			
Index - String	MIN value	MAX value	Parameter function
 F bAS	1 °C	20 °C	This parameter indicates the proportional band applied to the hot domestic water set; this band produces the optimised management of the compressor, only switching it on if the inlet/outlet water temperature (depending on the type of control set by parameter (0) in the installer menu) is less than the hot domestic water set (parameter (E) user menu), minus the value of this parameter. In cooling only units, this parameter is displayed but it cannot be modified.

 Parameter visible ONLY on units suitable for the production of hot water

 Parameter visible ONLY on units suitable for the production of DHW

 Parameter visible ONLY on units with condensation control device on board

 Parameter ONLY visible on units fitted with twin compressor

 Parameter ONLY visible on units fitted with inverter compressor

Alarms summary table

The units envision two types of malfunctioning signals:

- Pre-alarm
- Alarm

The first type is indicated by the flashing of the red LED on the display, successive pressing of the bell key allows to display

the list of alarms (with index and cause indicated in the table below). A pre-alarm remains such for 60 seconds: if after this time the condition that caused the pre-alarm has not disappeared, the same becomes an alarm. The alarms are displayed in the same way as the pre-alarms,

except for the switch-on of the fixed red LED. Before rearming the unit, it is recommended to contact the after-sales service. To rearm the unit, switch it off and back on again using the stand-by key.

ATTENTION:

The pre-alarms can become alarms when:

- A time has passed longer than or equal to 60 seconds, in the pre-alarm condition.
- The maximum number of pre-alarms in one hour (five) has been exceeded. In this case, every successive pre-alarm will be displayed directly as an alarm, and as such, will stop the machine until the reason for the same is solved.

Code Alarm	Code Pre-alarm	Causes	Notes
1	101	Compressor magnet circuit breaker	This signal intervenes if the contact relative to the magnet circuit breaker switch protecting the MTC compressor opens (Table 2, contact ID1, clamps M7.1 - M7.2, normally closed)
		Fan magnet circuit breaker	
		Pump magnet circuit breaker	
2	102	Fan magnet circuit breaker	This signal intervenes if the contact relative to the magnet circuit breaker switch protecting the MTV fans opens (Table 2, contact ID6, clamps M7S.3 - M7S.4, normally closed) This code is displayed only if the board is used as a board spare part with SW up to version 3.6.
3	103	High pressure switch	This signal DOES NOT give the state of the high pressure switch itself but of the compressor switch. The high pressure switch operates directly on the compressor switches. If the board commands compressor switch-on and the switch does not become active after 3 seconds, this signal occurs. This alarm can also be caused by an operating defect of the return relay from the compressor switch to the board (indicated as RAP in the wiring diagrams). This signal occurs if the compressor switch deactivates during operation. AP (Table 2, contact ID4, clamps M7.7 - M7.8, normally closed)
4	104	Flow switch	This signal occurs with the opening of the contact relative to the differential flow switch or pressure switch; this alarm is not relative for the first 40" from pump start-up. The machine blocks in alarm mode when the maximum number of flow switch interventions allowed (expressed by the set_factory parameter (y): default 5) is exceeded. If the frost protection in standby mode is activated (and therefore also the pump), the state of the flow switch is also controlled. FL/PD (Table 2, contact ID2, clamps M7.3 - M7.4, normally closed)
		Water differential pressure switch	
5	105	Low pressure switch	This signal intervenes when the contact relative to the low pressure switch opens (compressor intake). BP (Table 2, contact ID5, clamps M7S.1 - M7S.2)
6	106	No water inlet probe	This signal occurs when the water inlet probe is disconnected
7	107	No water outlet probe	This signal occurs when the water outlet probe is disconnected
8	108	Water freezing	This signal occurs when the anti-freeze threshold is reached (set_installer (6) default: 3°C) from the output water temperature. The pre-alarm state is exited with outlet water temperature exceeding the set_installer (6) + set_factory (J) (default 3+1=4°C). The anti-freeze alarm is suspended (in heating mode) for a period of time equal to 3' (set_factory parameter (H)) from compressor switch on.
9	109	No pressing line probe	This signal occurs when the pressing line gas probe is absent
10	110	High pressing line gas temperature	This signal occurs when the temperature of the pressing line gas (SGP probe) exceeds the threshold envisioned by the parameter (set_factory (6), default 135°C). The pre-alarm state is exited with set_factory (7) temperature (default 135 - 10 = 125 °C)
11	111	Flow pressure transducer no compressor	This signal occurs when the compressor flow transducer is absent and the machine is set as heat pump or the presence of the DCP is set

Code Alarm	Code Pre-alarm	Causes	Notes
12	112	High pressure	This signal occurs when the transducer detects a flow pressure over the set-factory parameter threshold (8) (default: 40 bar). The pre-alarm state is exited with set_factory (8) – set_factory (b) pressure (default 40 – 2 = 38 bar)
13	113	No defrosting probe	This signal occurs when the defrosting probe is absent and the machine is set as heat pump
14	114	Intake pressure transducer no compressor	This signal occurs when the compressor intake transducer is absent and the machine is set as heat pump
15	115	Low pressure	This signal occurs when the compressor flow transducer indicates an intake pressure below the threshold set by the set_factory (9) parameter in cooling mode (default 4 bar), set_factory(A) ion heating mode (default 2 bar). The pre-alarm state is exited when the intake pressure exceeds the intervention set_factory(b) threshold default equal to 2 bar. The low pressure alarm is suspended in heating mode for a period of time equal to 3' (set_factory parameter (H parameter) from compressor switch on. It is permanently suspended during cycle reverse
16	-	Low performance	Every time the machine is powered, the control checks compressor behaviour once via the yield control procedure (see 8.1); this control is disabled from dip switch
17	117	Pump magnet circuit breaker	This signal intervenes if the magnet circuit breaker switch protecting the pump is opened. MTP (table 2, contact ID3, clamps M7.5 – M7.6, normally closed). This code is displayed only if the board is used as a board spare part with SW up to version 3.6.
18	118	High pressure partialisation	This signal occurs every time a partialisation takes place due to the threshold mentioned in paragraph 8.5 being reached. The machine blocks in alarm mode when the maximum number of partialisation interventions allowed (expressed by the set_factory (5) parameter: default 5) is exceeded. With inverter machine mode, it also indicates a partialisation due to high compression ratio.
19	119	Low pressure partialisation	This signal occurs every time a low pressure partialisation takes place, par. 8.5. The machine blocks in alarm mode when the maximum number of partialisations allowed (expressed by the set_factory (5) parameter: default 5) is exceeded.
20	120	Pressing line temperature partialisation	This signal occurs every time a pressing line temperature partialisation takes place (par. 8.5), the machine blocks in alarm mode when the maximum number of partialisation interventions (expressed by the set_factory (5) parameter: default 5) permitted is exceeded.
21	121	Bemf error	Error in detection of the back emf. This error is returned by the inverter control board and is linked to compressor peak problems (longertek 4 code or longertek 20 code)
22	122	Internal communication error	The inverter control board has internal communication problems (longertek 5 code)
23	123	Over-current	Excess current absorption by compressor (longertek 6 code)
24	124	No load	The compressor does not absorb enough current, it may turn in idle mode (longertek 7 code)
25	125	Incorrect voltage	The inverter control board indicates incorrect bus voltage (longertek 8 code)
26	126	Error on start-up	The inverter control board indicates incorrect start-up of the PMSM motor (longertek code 9)
27	127	IPM protection error	Error on the IGBT (longertek 12 code)
28	128	EEPROM error	Eeprom error on the inverter control board (longertek 13 code)
29	129	Compressor stall	Code longertek 16
30	130	No communication	The inverter control board does not respond. It may not be powered or the serial cable could be disconnected or the A and B signals reversed
31	131	PFC Module	PFC inverter module error (longertek 23 code)
32	132	Cooling fin overheating	(code APY 1)
33	133	Over current in acceleration mode	Hardware error (cod. APY 2)
34	134	Over-current at constant speed	Hardware error (cod. APY 3)
35	135	Over current in deceleration mode	Hardware error (cod. APY 4)
36	136	Under-voltage on the DC Bus	(code APY 5)

Code Alarm	Code Pre-alarm	Causes	Notes
37	137	DC Bus over-voltage	(code APY 6)
40	140	PFC Converter Fault Error in the PFC module	Software error (code APY 9)
41	141	Over current in acceleration mode	Software error (code APY 10)
42	142	Overload	(code APY 11)
43	143	Over-current at constant speed	Software error (code APY 12)
44	144	Over current in deceleration mode	Software error (code APY 13)
45	145	Compressor not connected correctly	(code APY 14)
46	146	No communication	(code APY 15)
47	147	Cooling fin temperature sensor error	(code APY 16)
51	151	Anomalous condition	Protection frequency against over-current and overheating reduced. (code APY 20)
54	--	Cycle reverse valve faulty	The cycle reverse valve could be faulty or broken. (see 8.4)
55	155	Water inlet high temperature	The water inlet temperature has exceeded the set_installer (H) parameter value. Probable boiler presence on same plant. At the third intervention of the pre-alarm, the machine goes into alarm mode and blocks
--	156	Cycle reverse due to high temperature of the pressing line gas	This pre-alarm indicates the intervention of defrosting due to cycle reverse without having respected the times between cycle reverses. Cycle reverse has been triggered by the pressing line gas high temperature partialisation threshold being exceeded, set_factory (6)-set_factory (4) = default 130°. This pre-alarm does not cause compressor stop and does not have a limited number of interventions
57	157	Reading error of the DHW control board remote probe.	This pre-alarm indicates a remote probe fault or a communication problem with the DHW control board. The alarm is only active if the parameter (0)=2 or the parameter (8)=4 in the menu with password = 30
58	158	Outdoor air temperature probe reading error	This pre-alarm indicates an outdoor air temperature probe fault when the DCP is present or the machine is in heat pump mode.
59	159	Inlet water probe no condenser (ONLY WRL)	This pre-alarm indicates a condenser inlet water temperature probe fault
60	160	Output water probe no condenser (ONLY WRL)	This pre-alarm indicates a condenser outlet water temperature probe fault
61	161	Over-current	Carel Inverter
62	162	Compressor motor overload	Carel Inverter
63	163	Over-voltage	Carel Inverter
64	164	Under-voltage	Carel Inverter
65	165	Drive overheating	Carel Inverter
66	166	Drive underheating	Carel Inverter
67	167	Hardware over-current	Carel Inverter
68	168	Compressor overheating	Carel Inverter
69	169	Reserved	Carel Inverter
70	170	CPU error	Carel Inverter
71	171	Default parameters	Carel Inverter
72	172	DC bus ripple	Carel Inverter
73	173	No communication between inverter and uPC	Carel Inverter
74	174	Drive temperature sensor fault	Carel Inverter
75	175	Self-configuration failed	Carel Inverter
76	176	Inverter drive disabled	Carel Inverter
77	177	Motor phases error	Carel Inverter
78	178	Cooling fan Inverter faulty	Carel Inverter
79	179	Speed fault	Carel Inverter

Code Alarm	Code Pre-alarm	Causes	Notes
80	180	PFC fault	Alarm that occurs with PFC enabled while the bus DC is very low
81	181	PFC overload trip	This alarm will no longer be present in the new firmware versions.
82	182	Input voltage error	When the power supply drops below 170 V with engine running
83	183	Generic inverter error	Carel Inverter, carel modbus address 213
84	184	Probe B1 fault (uPC)	Control wiring
85	185	Probe B2 fault (uPC)	Control wiring
86	186	Probe B3 fault (uPC)	Control wiring
87	187	Probe B4 fault (uPC)	Control wiring
88	188	Probe B5 fault (uPC)	Control wiring
89	189	Probe B6 fault (uPC)	Control wiring
90	190	Probe B7 fault (uPC)	Control wiring
91	191	High pressure alarm (uPC)	Control wiring
92	192	Low pressure alarm (uPC)	Control wiring
93	193	Gas high temperature alarm pressing line (uPC)	Control wiring
94	194	Pressure differential lower than that specified (uPC)	Control wiring
95	195	Compressor start-up failed (uPC)	Control wiring
96	196	Time exceeding operational limits alarm (uPC)	Control wiring
97	197	Super Heat low alarm (uPC)	Control wiring
98	198	MOP alarm (uPC)	Control wiring
99	199	Low intake temperature alarm (uPC)	Control wiring
200	300	EVD EVO alarm: Evtunes alarm (uPC)	Control wiring
201	301	EVD EVO regulation alarm (uPC)	Control wiring
202	302	EVD EVO system alarms probe errors alarm (uPC)	Control wiring
203	303	Reserved. (uPC)	Control wiring
204	304	No communication between inverter and uPC. (uPC error)	Control wiring
205	305	Inverter not compatible with the compressor selected (uPC)	Control wiring
206	306	Delta P greater than the permit at start up (uPC)	Control wiring
207	307	Low pressure limit	Discharged unit

ATTENZIONE:

Si ricorda che i preallarmi sono a riarmo automatico, mentre gli allarmi sono a riarmo manuale.

Dalla versione software 3.9.0 è stato introdotto il reset degli allarmi tramite contatto remoto di ON/OFF se abilitato.

Da posizione on, se passa in off e ritorna in on entro 5 secondi resetta gli allarmi; tramite il contatto ON/OFF è possibile eseguire al massimo 3 reset ogni ora.

Prima bisogna resettare gli allarmi con tasto "R".

In caso di mancanza di tensione vengono resettati gli allarmi.