

OmniaRadiant

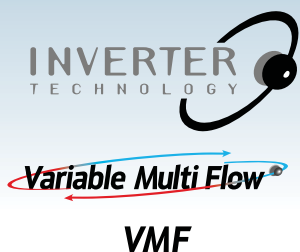

FAN COIL UNITS - Installation and maintenance manual

FAN COIL UNITS

- VERTICAL INSTALLATION
- VENTILATED HEATING
- LOW TEMPERATURE RADIANT HEATING
- COOLING / DEHUMIDIFICATION
- LOW OPERATING TEMPERATURE

Omnia UL_R-UL_RI

EN



1.	General warnings for the installer	22
1.1.	Conservation of documentation	22
1.2.	Safety warnings and installation standards	22
1.3.	Product identification	22
2.	Receiving the unit	23
2.1.	Checks on reception.....	23
3.	Dimensions and minimum clearance spaces.....	23
3.1.	Dimensions	23
3.2.	Minimum clearance spaces.....	23
4.	Wall or floor installation	24
5.	Pipe connections.....	25
5.1.	Hydraulic connections.....	25
5.2.	Condensate drain	25
6.	Electrical connections	26
6.1.	Electrical connections by the installer	27
6.2.	Dip-switch settings	27
6.3.	Network settings	28
7.	Installation of the electrostatically precharged filter	28
8.	Maintenance	29
8.1.	Routine maintenance.....	29
8.2.	Special maintenance	29
9.	Problems and solutions.....	29

IMPORTANT INFORMATION

WARNING:
The OMNIA fan coil units are designed for internal installation.

WARNING: The fan coil unit is connected to the power supply and a water circuit. Operations performed by persons without the required technical skills can lead to personal injury to the operator or damage to the unit and surrounding objects.

WARNING: Components sensitive to static electricity can be damaged by voltages well below human perception. These discharges occur when touching a component or electrical contact without first discharging the body of any accumulated electrical charge. The damage caused by static discharge is not immediately perceptible and may manifest only after a certain period of operation.

ACCUMULATION OF STATIC ELECTRICITY
Any person without a conductive connection to the ambient electrical potential can accumulate static electricity.

BASIC PROTECTION AGAINST ELECTROSTATIC DISCHARGES

Quality of earthing

When operating on units sensitive to static electricity ensure that the person, the workplace and the covers of the unit are correctly earthed. In this way the formation of static charges is avoided.

Avoid direct contact

Only touch the exposed sensitive parts if absolutely necessary, such as during maintenance.

Do not touch the contact pins or printed circuit board. By following this advice the electrostatic discharge cannot reach or damage the sensitive parts.

If measurements have to be taken from the unit it is important to electrically discharge the body

before carrying out any operation, by touching a metal object connected to the earth. Only use earthed instruments.

POWER THE FAN COIL UNIT ONLY WITH 230 VOLT SINGLE PHASE

Use of other power supplies could cause permanent damage to the fan coil unit.

DO NOT USE THE FAN COIL UNIT IMPROPERLY

Do not use the fan coil unit in animal husbandry applications.

VENTILATE THE ROOM

Periodically air the room in which the fan coil unit has been installed; this is particularly important if the room is occupied by many people, or if gas appliances or sources of odours are present.

CORRECTLY CONTROLLING THE TEMPERATURE

The room temperature should be controlled in order to provide maximum comfort to the people in the room, especially if they are elderly, children or ill, avoiding sudden changes in temperature between the outside and inside above 7 °C in summer.

Lower temperature in the summer means higher electrical consumption.

CORRECTLY ADJUSTING THE AIR JET

The air coming out of the fan coil unit must not strike people directly; in fact, even if at a temperature that is higher than the room temperature, it could cause a cold sensation and resulting discomfort.

DURING OPERATION

Always leave the filter in the fan coil unit during operation otherwise dust in the air will dirty the surfaces of the coil.

WHAT IS NORMAL

During cooling, water vapour may be present in the air discharge.

During heating it might be possible to hear a slight hiss around the fan coil unit. Sometimes the fan

coil unit might give off unpleasant smells due to the accumulation of substances from the air of the room (especially if the room is not ventilated regularly. Clean the filter more often).

During operation, there could be noises and creaks inside the device, due to the thermal expansion of the various components (plastic and metallic), but this does not indicate a malfunction and does not cause damage to the unit unless the maximum inlet water temperature is exceeded.

MALFUNCTIONS

In the case of a malfunction remove power to the unit then reapply it and start the unit again. If the problem occurs again, call your area After-Sales service department promptly.

DO NOT PULL THE ELECTRICAL CABLE

It is very dangerous to pull, tread on or crush the electrical power cable or fix it with nails or drawing pins.

A damaged power cable can cause short circuits and personal injury.

DO NOT PUT ANYTHING IN THE AIR OUTLETS

Do not put anything at all in the air outlet slots. This could cause injury to people and damage to the fan.

OPERATING LIMITS

Model OMNIA UL_R - UL_RI	26-36
Ambient temperature limits	0°C<Ta<40°C
Ambient humidity maximum limit	<85% RH
Maximum water inlet temperature	80°C
Maximum operating pressure	8 bar
Protective rating	IP20

SAFETY SYMBOLS

Danger



Moving parts



Electrical danger

1. GENERAL WARNINGS FOR THE INSTALLER

The Omnia UL_R and UL_RI units are manufactured in accordance with recognised technical standards and safety regulations. It is a terminal unit which contains, within one device, the best solution for heating, cooling and dehumidification. They must be used for the purpose for which they are intended and compatible with their performance characteristics. All contractual and extra-contractual liabilities for damage caused to persons, animals or objects or through errors of installation, control or maintenance or from improper use are excluded by the Company. Any uses not expressly indicated in this manual are not permitted.

1.1. CONSERVATION OF DOCUMENTATION

1. Consign the instructions with all the complementary documentation to the user of the unit who will assume responsibility for the conservation of the instructions so that these are always available in case of need.
2. Carefully read this document. The execution of all the works must be carried out by qualified personnel, in accordance with the national regulations.
3. Do not modify or tamper with the unit as this may cause danger for which the manufacturer will not accept any responsibility for any damages caused. The warranty is voided if the above

instructions are not followed.

1.2. SAFETY WARNINGS AND INSTALLATION STANDARDS

1. The unit must be installed by a competent and qualified technician, and in accordance with the legislation applicable in the country of installation. Aermec assumes no responsibility for damage caused by failure to observe these instructions.
2. Before commencing any works it is necessary to **CAREFULLY READ THE INSTRUCTIONS AND MINIMISE ANY RISKS BY TAKING APPROPRIATE SAFETY PRECAUTIONS**. All relevant personnel must be made aware of the procedures and possible risks that may arise at the time of installation of the unit.
3. The unit must be installed in such a way to make maintenance and/or repair functions possible.

1.3. PRODUCT IDENTIFICATION

The fan coil units are identified by:

- PACKING LABEL that records the product identification label
- NAMEPLATE

Radiant technology under licence

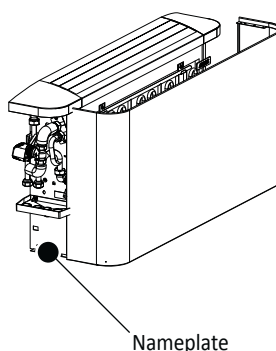

WARNING:
The tampering, removal or absence of the identification label renders difficult any operation of installation or maintenance.

2. RECEIVING THE UNIT

The fan coil units are shipped with standard packaging consisting of expanded polystyrene shells and cardboard.

2.1. CHECKS ON RECEPTION

On receiving the unit it is required to check that:

- the packages correspond to that shown on the document accompanying the goods
- the packaging is intact
- the unit and panels are undamaged
- all components are present.

In the event that damage is noticed or components are missing, this must be recorded on the transport documents.

AMBIENTE DI FUNZIONAMENTO

Le unità sono state progettate per installazione in ambienti chiusi in condizioni di atmosfera 'urbana' non marina ed avente caratteristiche di non corrosività e di non polverosità. Per nessun motivo devono essere superate le seguenti concentrazioni di fattori inquinanti nell'aria in cui l'unità deve operare:

SO ₂	<0,02 ppm
H ₂ S	<0,02 ppm
NO,NO ₂	<1 ppm
NH ₃	<6 ppm
N ₂ O	<0,25 ppm

L'unità non deve venire installata in posizioni caratterizzate dalla presenza di gas infiammabili o di sostanze a carattere acido o alcalino.

In caso contrario le batterie ed i componenti interni degli apparecchi potrebbero subire gravi ed irreparabili danni di corrosione.

3. DIMENSIONS AND MINIMUM CLEARANCE SPACES

3.1. DIMENSIONS

Model OMNIA UL_R - UL_RI		26	36
Height	A (mm)	606	606
Width	B (mm)	980	1200
Depth	C (mm)	173	173
Foot height (Accessory "ZU")	D (mm)	93	93
Weight ⁽¹⁾	(kg)	20	24

(1) Standard configuration unit without accessories.

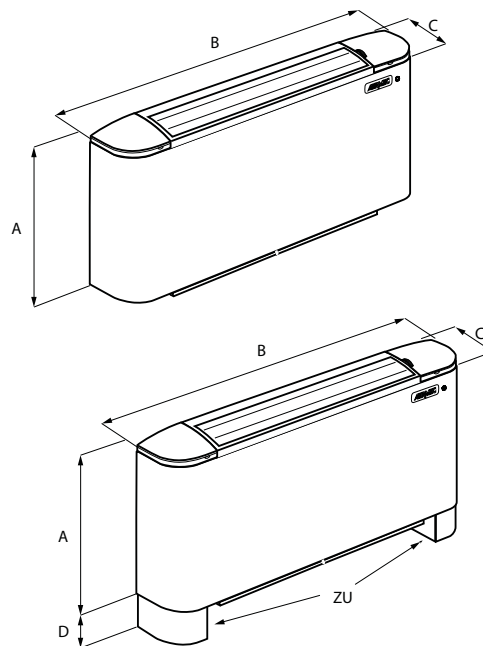

3.2. MINIMUM CLEARANCE SPACES

Model OMNIA UL_R - UL_RI		26	36
CLEARANCE	E (mm)	50	50
	F (mm)	93	93
	G (mm)	220	220
	H (mm)	200	200

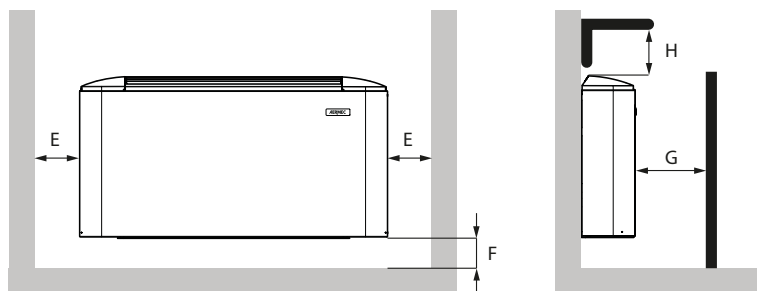

AVVERTENZE PER LA QUALITÀ DELL'ACQUA CIRCOLANTE NELLE BATTERIE

Si consiglia di fare eseguire un'analisi dell'acqua circolante nella batteria focalizzata sulla ricerca dell'eventuale presenza di batteri (rilevamento dei ferrobatteri e dei microrganismi che possono produrre H₂S o ridurre chimicamente i solfati) e sulla composizione chimica dell'acqua stessa in modo da prevenire fenomeni di corrosione e incrostazione all'interno dei tubi. Il circuito dell'acqua deve essere alimentato e reintegrato con acqua trattata che non superi i livelli di soglia sotto indicati.

Durezza totale in mmol/l	l < mmol/l < 1,5
Cloruri [CL ⁻]	< 10 mg/litro
Solfati [SO ₄ ²⁻]	< 30 mg/litro
Nitrati [NO ₃ ⁻]	= 0 mg/litro
Ferro Dissolto	< 0,5 mg/litro
Ossigeno Dissolto	4 < [O ₂] < 9 mg/litro
Anidride Carbonica [CO ₂]	< 30 mg/litro
Resistività	20 Ohm·m < Resistività < 50 Ohm·m
pH	6,9 < pH < 8

4. WALL OR FLOOR INSTALLATION

4.2.1. DESCRIPTION

The components for the unit installation are contained in the packaging.
Before proceeding with the installation open the packaging and remove the items contained inside:

- Omnia UL_R or Omnia UL_RI, assembled.
- Electrostatic filter material.

4.2.2. INSTALLATION

- Remove the casing by unscrewing the screws.
- For floor mounting ensure a minimum clearance of 80 mm from the ground. **For floor mounting with the foot accessory refer to the instructions supplied loose with the accessory.**
- For wall mounting the support structure must be completely flat. Use four expansion plugs (not supplied) suitable for the wall, to attach the unit.

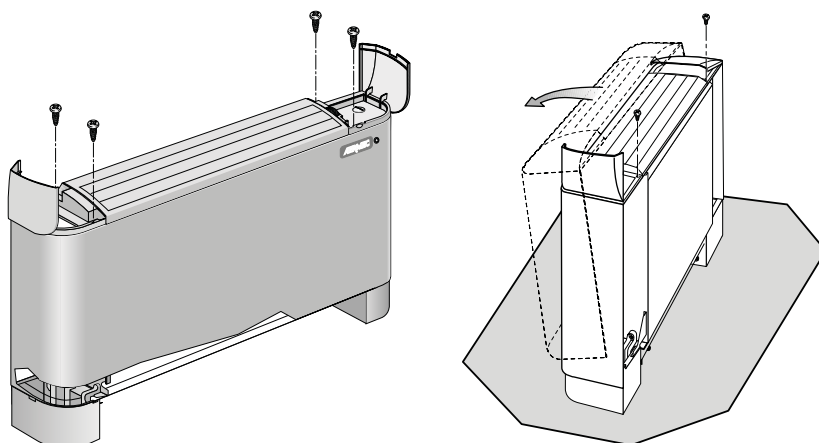

Model OMNIA UL_R - UL_RI	26	36
A	(mm) 980	1200
B	(mm) 725	945
C	(mm) 701.5	921.5
D	(mm) 629	849
E	(mm) 735	955

1	Adjustable discharge louvres
2	Casing
3	Main structure
4	Foot (accessory)
5	Connection space

- Attach any accessories.
- To modify the electronic thermostat dip-switch settings access through the panel on the side of the unit (see chapter ELECTRICAL CONNECTIONS "DIP-SWITCH SETTINGS").
- Carry out all connections.
- Mount the casing.
- Check the correct operation of the fan coil unit.
- Fit the air filter. The filter is supplied in sealed packaging, to be opened only at the time of use.

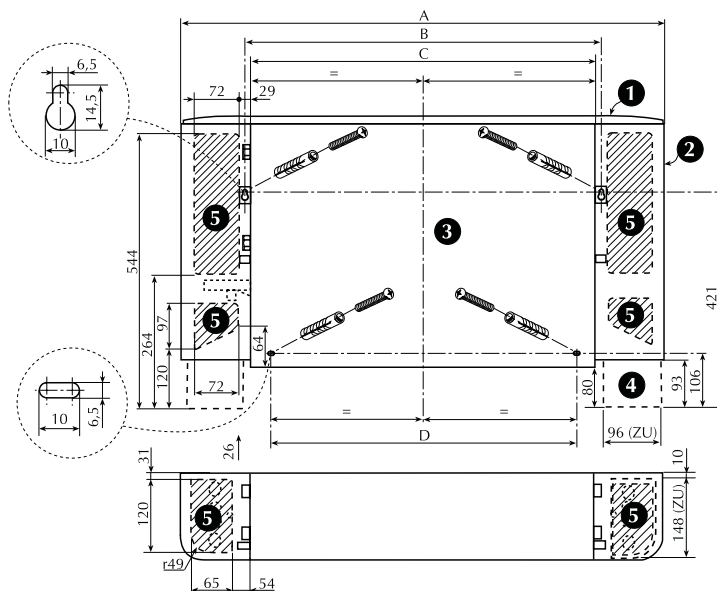

WARNING

The support structure must be completely flat. Use four expansion plugs (not supplied) suitable for the wall, to attach the unit.

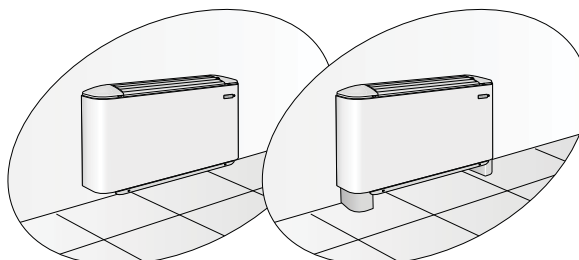

WALL MOUNTED

WALL MOUNTED WITH FEET ZU (accessory)

5. PIPE CONNECTIONS



WARNING
Only left hand pipe connections are possible and the coil cannot be reversed.

5.1. HYDRAULIC CONNECTIONS

Ensure the water piping, condensate drain and electrical circuit are already installed.

The selection and sizing of the pipework is the responsibility of the designer, which must be in accordance with good practices and applicable legislation.

Always use a counter-spanner when fixing pipe-work with a spanner.

It is recommended that pipework is suitably insulated to prevent condensation in cooling mode, even if the Omnia UL_R and UL_RI have a condensate drain tray as standard. Carry out a leak test of all hydraulic connections.

IN	Water inlet
OUT	Water outlet
SF	Air vent
SC	Water drain

Model OMNIA UL_R - UL_RI	26	36
Water flow rate	(l/h) 349	487
Coil water content	(l/h) 0.8	1.1
Coil connections (in/out)	(inch) 1/4"	1/4"

5.2. CONDENSATE DRAIN

In cooling mode the unit removes humidity from the internal air. This condensate must be removed by connecting the unit's condensate drain outlet to the condensate drain system.

Note:

Before connecting the condensate drain, pierce the diaphragm of the drain pan, on the hydraulic connections side, with a suitable tool. Seal the drain hole not used.

Connect the drain pan discharge to the condensate drain system with a drain tube. The drain pan connection is only designed for use with flexible tubes of adequate internal diameter. Avoid imposing any loads and do not use for any other purpose.

The condensate drain system must be adequately sized and the piping arranged to ensure a sufficient incline along the length (minimum 1%). If connected to the sewerage system it is recommended that a trap is used to prevent odours rising into the space.

INSTALLATION EXAMPLES

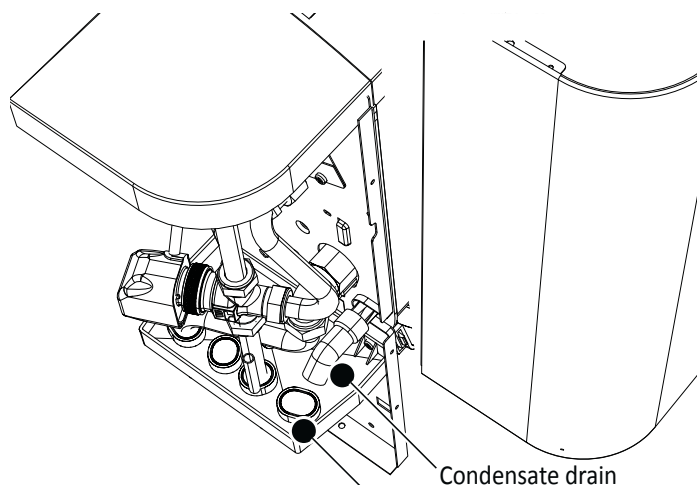
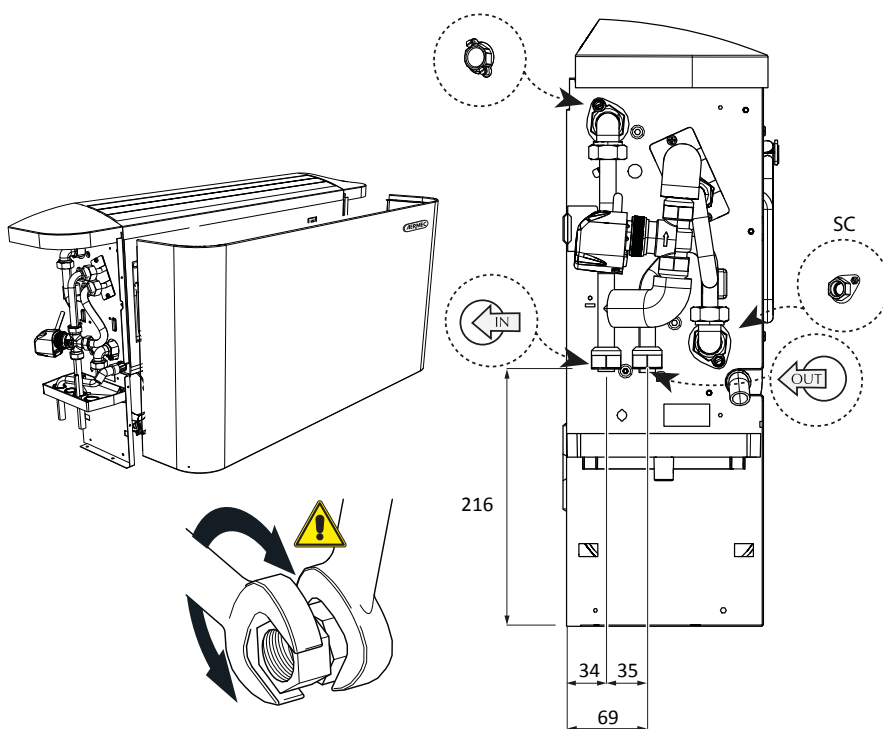
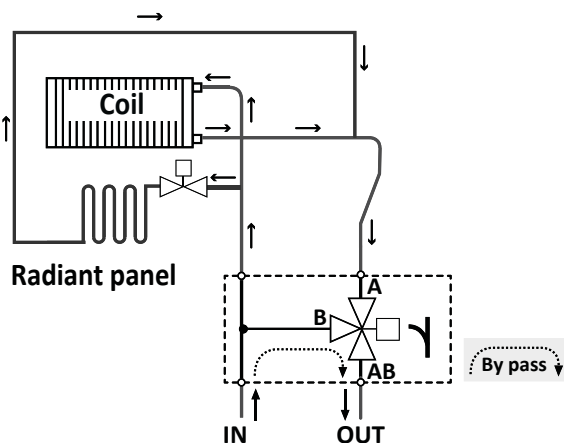

WARNING
Leak test the condensate drain.

Drain pan diaphragm for discharge of the condensate drain

6. ELECTRICAL CONNECTIONS

Warning:

Before carrying out any operation ensure that the electrical power is disconnected.

The fan coil units are provided with the following controls:

VMF-E0R for UL_R

VMF-E18R for UL_RI

In either case they are located on the right hand side of the fan coil units (fig.01) and protected by a plastic box. The connections have to be made directly onto the electronic circuit board.

Attention:

The wiring schematic showing terminal connections for the electronic circuit board are printed on the inside of the plastic box cover. (fig.02)

The unit must be connected directly to an electrical connection or an independent circuit.

The fan coil units Omnia UL_R and UL_RI are supplied with 230V/1/50Hz and earth connection. The line voltage must remain within the tolerance of $\pm 10\%$ of nominal values.

The power supply cable must be of type H07 V-K or N07 V-K with insulation of 450/750V if protected by a conduit or tubing. For exposed cables use double insulated cables of type H5VV-F.

All cables must be protected by a conduit or tubing until they are inside the fan coil unit. The cables exiting the conduit or tubing must be positioned so they are not subjected to tension or twisting and must be protected from external effects.

Wiring diagrams are subject to continual updates so it is mandatory to refer to those on the unit.

For all connections refer to the wiring diagrams supplied with the unit and shown in this documentation.



All electrical works must be carried out by PERSONNEL WITH THE APPROPRIATE LEGAL QUALIFICATIONS, trained and aware of the risks relating to such works.



The design of the cabling and related components must be carried out by PERSONNEL WITH APPROPRIATE QUALIFICATIONS TO DESIGN ELECTRICAL INSTALLATIONS, following international and national standards of the location the unit is installed in accordance with current legal requirements.



For installation details refer to the electrical wiring schematics supplied with the unit. The electrical wiring schematic together with the manuals must be conserved with care and MADE AVAILABLE FOR FUTURE REFERENCE.



The seals of the equipment must be checked before making electrical connections and the unit must only be powered on completion of all electrical and hydraulic works.

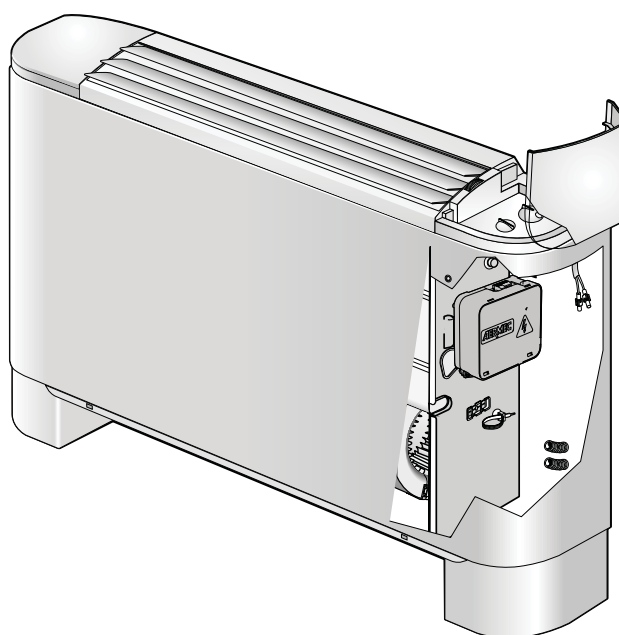

(fig.01)

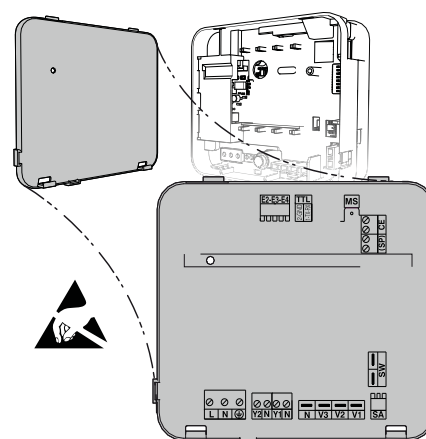

(fig.02)

6.1. ELECTRICAL CONNECTIONS BY THE INSTALLER

The fan coil units are completely factory wired and the following connections are the responsibility of the installer (fig.3):

- Connect the power supply and earth cable downstream of a protective isolator in accordance with applicable wiring regulations.
- Connect the isolating solenoid valve, if supplied.
- Connect the network cables (if networked).
- Connect the external contact cables (if required).
- Check all connections are correctly tightened and fixed.

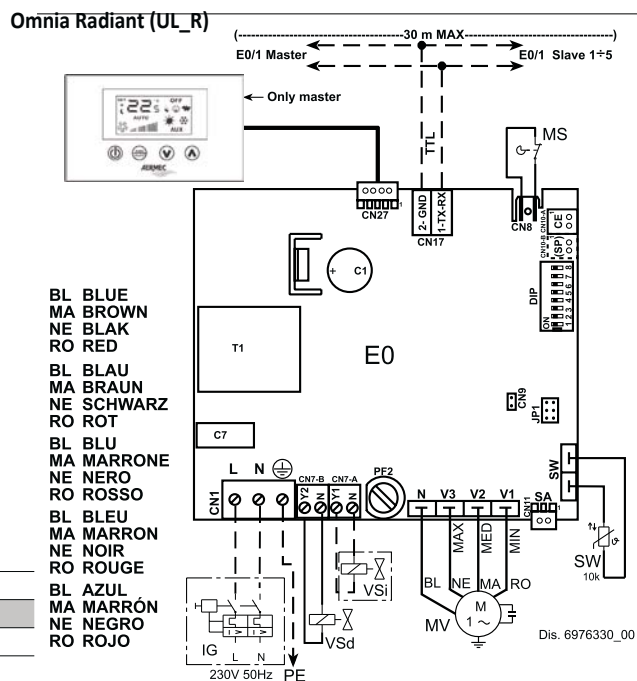

RECOMMENDED CABLES FOR ELECTRICAL CONNECTION

For electrical power supply		
Cable type	Installation type	Recommended section
H07 V-K or N07 V-K with insulation 450/750V	conduit or tube	min/max. 0.5/2.0 mm ²
H5VV-F with double insulation	exposed cable	min/max. 0.5/2.0 mm ²
For earth connection		
Cable type	Installation type	Recommended section
Standard	any	min/max. 0.5/2.0 mm ²

6.2. DIP-SWITCH SETTINGS

The electronic circuit board has dip-switch settings for various installation options. There are eight dip-switches and each of their function is described in the adjacent table.

Position	Function
Dip 1 (Default OFF)	Water valve control:
OFF	Without water isolating valve
ON	With water isolating valve
Dip 2 (Default OFF)	Radiant heating control:
OFF	Radiant heating as replacement
ON	Radiant heating as supplementary
Dip 3 (Default OFF)	Not used
OFF	-
ON	-
Dip 4 (Default OFF)	Ventilation enabling:
OFF	Normal range enabling
ON	Reduced range enabling
Dip 5 (Default OFF)	ΔT setting
OFF	Combination between Dip 5 and Dip 6 see (fig.4)
ON	Combination between Dip 5 and Dip 6 see (fig.4)
Dip 7 (Default OFF)	Dead-band:
OFF	Dead-band 5K
ON	Dead-band 2K
Dip 8 (Default OFF)	Not used
OFF	-
ON	-

(fig.03)

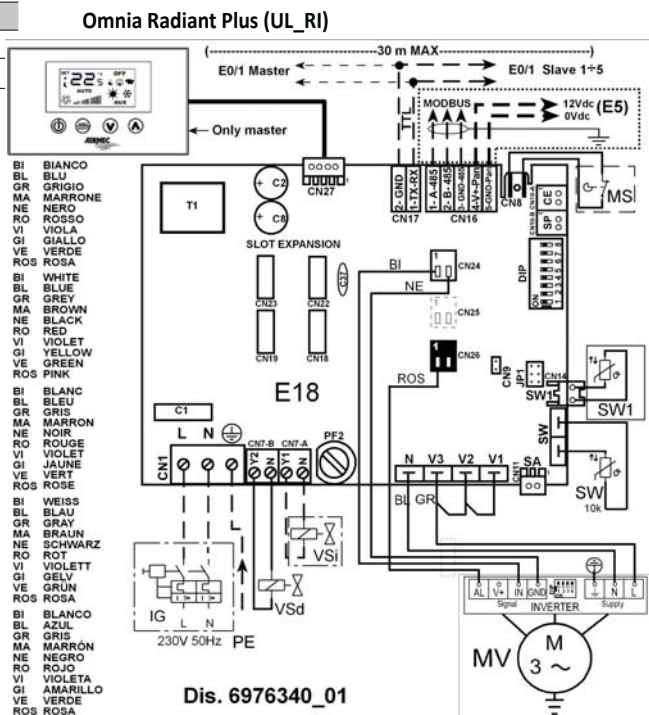

Dip 6	Dip 5	ΔT
Off	Off	0.5K
Off	On	0.8K
On	Off	1.2K
On	On	1.5K

(fig.04)

Legend

L	Line
N	Neutral
PE	Earth
VSi	Isolating solenoid valve
VSd	Diverting solenoid valve
MV	Fan motor
SW	Water sensor
MS	
TTL	TTL serial network
BL	Blue
NE	Black
MA	Brown
RO	Red

6.3. NETWORK SETTINGS

The VMF-E0R/VMF-E18R thermostats are designed to communicate with the remote control panel of the same VMF-E4 family (mandatory accessory).

The serial communications protocol is Modbus and a TTL network, which is used for the exchange of information within a small network of fan coil units between one and six units, of which one is Master and a maximum of five are Slaves.

The Master fan coil unit is the one connected to the VMF-E4 control panel, and sets the following points:

- Control setpoint.
- Operating mode.

Off: Units off.

AUTO: The thermostat maintains the temperature setpoint by changing the fan speed in Automatic Mode, as a function of the space temperature relative to the setpoint.

V1: The thermostat maintains the temperature setpoint by On-Off cycles only using the Minimum Speed of the fan.

V2: The thermostat maintains the temperature setpoint by On-Off cycles only using the Medium Speed of the fan.

V3: The thermostat maintains the temperature setpoint by On-Off cycles only using the Maximum Speed of the fan.

AUX: The thermostat forces into heating mode and maintains the temperature setpoint through

STAND ALONE application:

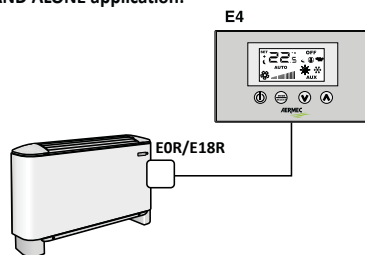

ZONE CONTROLLED application

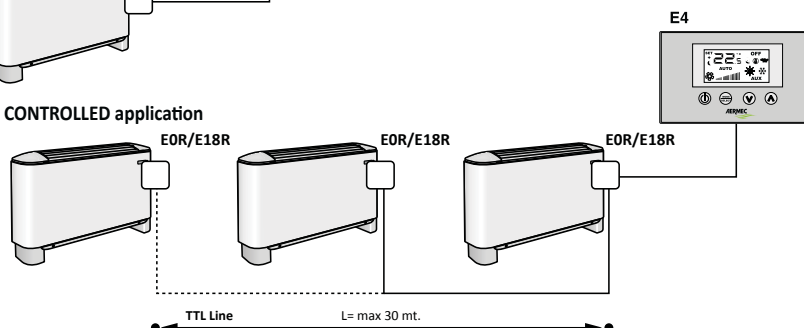

the use of radiant heating and convective heating from the heat exchanger, inhibiting the ventilation.

- Operating season.
- Ambient sensor.

The Slave fan coil units cannot operate with different settings to the Master's.



WARNING:

For further information on the use and installation of the VMF-E4 control panel refer to the accessory documentation.

7. INSTALLATION OF THE ELECTROSTATICALLY PRECHARGED FILTER

• Installation

- Remove the filter frame from the unit intake.
- With the point of a suitable tool press on the internal hooks of the grille.
- Remove the filter from the sealed packaging.
- Insert the filter within the air intake grille.
- Reassemble the filter frame.
- Refit the filter frame to the unit intake.

• Characteristics

Class 2 (UL 900) fire resistance.

Easily extracted. The filter is supplied in sealed packaging to be opened only at the time of use.

The electrostatically precharged filter lasts two years from the time of opening the sealed packaging, after which time it acts like a normal filter. For this reason it is recommended to replace the filter after two years. Replacement filters are available from Aermec service centres.

• Maintenance

Clean frequently. Remove any accumulated dust with a vacuum cleaner. The use of water or detergents greatly accelerates the discharge of the electrostatic effect.

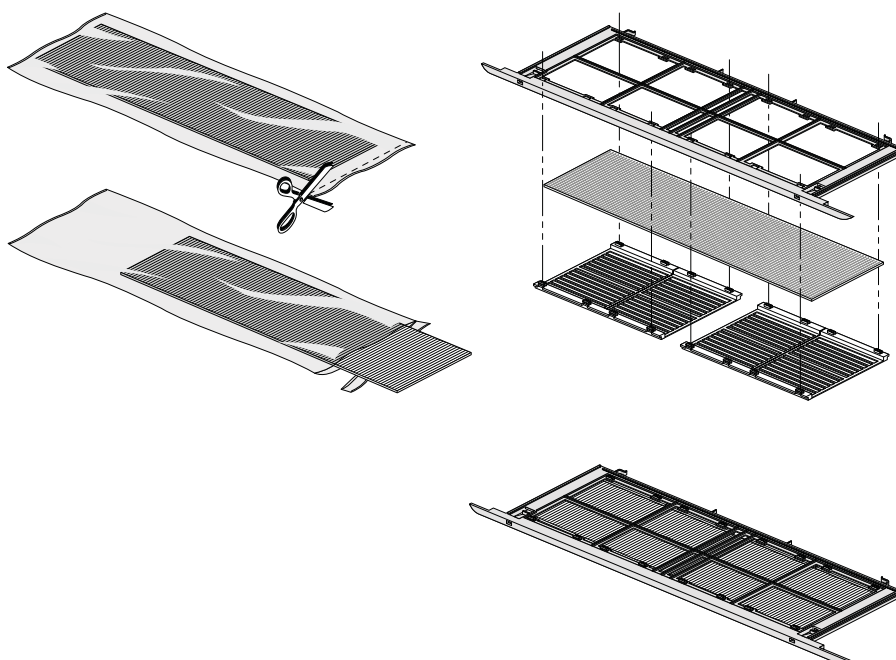

8. MAINTENANCE

8.1. ROUTINE MAINTENANCE

The routine maintenance can be performed by the user and consists of some simple operations which will ensure the fan coil unit operates at the maximum efficiency.

Operations:

- Externally clean every week with a damp cloth and neutral soap; avoid any other type of detergents or solvent.
- Weekly cleaning, if installed in dusty environments, or fortnightly cleaning of the electrostatically precharged filter with a vacuum cleaner to remove the dust. Cleaning with running water and neutral soap is permitted but this greatly accelerates the discharge of the electrostatic effect; avoid any other type of detergents or solvents.
- Replace the electrostatically precharged filter every two years. Outside of two years the electrostatic charge will be exhausted and the filtration of micro-dust will stop; the filtration capacity will be equivalent to a normal filter.

- Visual inspection of the fan coil unit state at every maintenance operation; any anomaly must be advised to the service centre.

8.2. SPECIAL MAINTENANCE

The special maintenance must only be carried out by the Aermec service centre technicians or personnel with the technical and professional expertise qualifying them to undertake installation, modification, expansion and maintenance of the systems and are able to check them in terms of safety and functionality.

The special maintenance consists of a series of complex operations which involve the disassembly of the fan coil unit or its components after which the fan coil unit will be returned to maximum operating efficiency.

It is important to undertake annual checks for the following:

Electrical checks:

- Measuring the insulation resistance of the electrical system.

- Continuity check of the protective conductors.

Mechanical checks:

- Internal cleaning annually or before prolonged shut-down periods; in areas where a higher level of air cleanliness is required this may be done more frequently. Cleaning is of the coil, the demountable fan housing, the blades of the fan, the drain pan and all the parts in contact with the treated air.
- Tightening of screws. Loose screws are the source of abnormal noise and vibration.

Before contacting the Aermec service centre for repairs or setting up, refer to the "PROBLEMS AND SOLUTIONS" chapter of this manual.

9. PROBLEMS AND SOLUTIONS

PROBLEM	CAUSE	SOLUTION
Low supply air flow	• Wrong fan speed setting on the control panel	• Select the correct fan speed on the control panel
	• Dirty filter	• Clean the filter
	• Air flow obstruction (inlet and/or outlet)	• Remove the obstruction
Does not heat	• No hot water	• Check the boiler/heat pump unit
	• Wrong control panel setting	• Set the control panel correctly
	• Air flow obstruction (inlet and/or outlet)	• Remove the obstruction
Does not cool	• No cold water	• Check the chiller/heat pump unit
	• Wrong control panel setting	• Set the control panel correctly
The fan does not rotate	• Power missing	• Check the electrical power supply
	• The water has not reached operating temperature	• Check the boiler/chiller/heat pump unit • Check the thermostat setting
Condensation on the external structure of the unit	• The temperature and humidity limits described in "OPERATING LIMITS" have been exceeded	• Raise the water temperature above the limits described in "OPERATING LIMITS"



WARNING

For problems not detailed, immediately call the service centre.