

SHERPA **A Q U A D U E**[®]

The **multifunctional** air-water split heat pump.



PATENTED TECHNOLOGY

The combination of an inverter air-water heat pump together with a water-water heat pump allows heating/cooling and high temperature DHW production, independently from the outside weather conditions.

COP > 4

DHW 75°C

Energy class: 35° **A+** 55° **A+**

FEATURES

DHW (Domestic Hot Water) production at a high temperature, up to 75 ° C.

DHW management: a group of water-water heat pumps integrated in the indoor unit provides domestic hot water at a high temperature regardless of external weather conditions.

Continuous absolute availability of DHW: guaranteed by the redundancy of the double refrigerating circuit system.

Antilegionella cycles avoidable using the refrigeration cycle at high temperature.

2-stage electric heater: single or double strength activation to support the heat pump through a simple configuration of the electronic control.

Each stage is activated according to the actual need of thermal power in order to optimize power consumption.

Configurable points: two set points in cooling mode Three set points in heating mode (one of them for DHW): the set points are also selectable by remote contact.

Weekly programmer DHW, holidays and daily with night mode.

Climatic curves with outside air temperature sensor: two curves are available, one for cooling and one for heating. Climatic curves allow you to modify system water temperature supply depending on climate conditions, adapting the heat requirements of the building in order to obtain energy savings.

Refrigerant gas: R410A* for the reversible circuit dedicated to air-conditioning and R134a** for the high temperature circuit dedicated to DHW production.



DHW AND COMFORT AT THE SAME TIME

The two interconnected refrigerator cycles allow the decoupling of the heating/cooling from the DHW production, enabling them to operate in parallel, avoiding thus interruptions in the domestic comfort supply.



75°C DOMESTIC HOT WATER

High teZ performed through the use of electrical resistances.



TOUCH SCREEN USER INTERFACE

Sherpa AQUADUE[®] control is extremely flexible and configurable, and it allows to:

- customize the response limits of the two cycles at installation
- customize comfort and DHW needs at installation
- optimize energy performances by managing the operation of the double refrigeration circuit.



Compatible with:



* non hermetically sealed equipment containing fluorinated gas with GWP equivalent 2088 -

** non hermetically sealed equipment containing fluorinated gas with GWP equivalent 1430

SHERPA

A Q U A D U E[®]

		AQUADUE 7	AQUADUE 11	AQUADUE 13	AQUADUE 13T	AQUADUE 16	AQUADUE 16T
Indoor unit	Code	599510A		599506A			
Outdoor Unit S1	Code	OS CESH24EI	OS CESH36EI	OS CESH48EI	OS CESH48EI	OS CESH60EI	OS CESH60EI
Refrigerant/water exchanger		Brazed plates	Brazed plates	Brazed plates	Brazed plates	Brazed plates	Brazed plates
Heating capacity (a)	kW	6,50	10,50	12,50	12,50	14	16
COP (a)	W/W	4,12	4,14	4,12	4,12	4,11	4,11
Heating capacity (b)	kW	4,30	7,20	8	8	8,50	9,20
COP (b)	W/W	2,60	2,65	2,70	2,70	2,40	2,50
Heating capacity (c)	kW	6,50	9,90	12,50	12,50	13,30	14
COP (c)	W/W	3,40	3,14	3,21	3,21	3,10	3,10
Heating capacity (d)	kW	3,80	6,20	7,20	7,20	8,50	9
COP (d)	W/W	2,30	2	2,10	2,10	2,10	2,10
Cooling capacity (e)	kW	7,90	11,80	12,30	12,50	13,50	15
EER (e)	W/W	4,50	4,40	4	4,10	3,80	4
Cooling capacity (f)	kW	5,60	8,10	10,40	10,40	11,30	12,80
EER (f)	W/W	3,10	3,08	3	3	2,70	2,80
Energy efficiency class heating mode 35°/55 °C		A+	A+	A+	A+	A+	A+
DHW circuit heating capacity (g)	kW	2,15	2,15	2,15	2,15	2,15	2,15
COP (g)	W/W	3,12	3,12	3,12	3,12	3,12	3,12
DHW circuit heating capacity (h)	kW	1,60	1,60	1,60	1,60	1,60	1,60
COP (h)	W/W	2,58	2,58	2,58	2,58	2,58	2,58
Sound pressure of indoor unit (i)	dB(A)	35	35	35	35	35	35
Sound power indoor unit	dB(A)	41	41	41	41	41	41
Sound power of indoor unit in heat. or cool. and DHW mode	dB(A)	47	47	47	47	47	47
Sound pressure outdoor unit (l)	dB(A)	54/55	56/58	60/60	60/60	60/60	60/62
Sound power outdoor unit	dB(A)	64/65	66/68	70/70	70/70	70/70	70/72
Diameter refrigerant connections	"	3/8-5/8	3/8-5/8	3/8-5/8	3/8-5/8	3/8-5/8	3/8-5/8
Circulator absorption DHW	W	16-43	16-43	16-43	16-43	16-43	16-43
System circulator absorption	W	40-130	40-130	40-130	40-130	40-130	40-130
Capacity of expansion vessel	l	8	8	8	8	8	8
Power supply of indoor unit	V/ph/ Hz	230/1/50	230/1/50	230/1/50	230/1/50	230/1/50	230/1/50
Maximum current absorption indoor unit (electrical heaters activated)	A	18,0	18,0	31,0	31,0	31,0	31,0
Maximum current absorption indoor unit (electrical heaters deactivated)	A	5,0	5,0	5,0	5,0	5,0	5,0
Additional electrical heater elements	kW	1,5 + 1,5	1,5 + 1,5	3 + 3	3 + 3	3 + 3	3 + 3
Hydraulic connections	"	1	1	1	1	1	1
Outdoor unit power supply	V/ph/ Hz	230/1/50	230/1/50	230/1/50	400/3/50	230/1/50	400/3/50
Outdoor unit maximum absorbed current	A	13,50	22	28	8,15	28	11,50
Refrigerant gas (system circuit) (m)		R410A	R410A	R410A	R410A	R410A	R410A
Refrigerant gas charge (outdoor unit)	Kg	1,95	3,20	4,00	4,00	4,00	4,30
Refrigerant gas (DHW circuit) (n)		R134a	R134a	R134a	R134a	R134a	R134a

(a) Heating mode, inlet/outlet water temperature 30°C/35°C, outdoor air temperature 7°C d.b./6°C w.b.
 (b) Heating mode, inlet/outlet water temperature 30°C/35°C, outdoor air temperature -2°C d.b./-1°C w.b.
 (c) Heating mode, inlet/outlet water temperature 40°C/45°C, outdoor air temperature 7°C d.b./6°C w.b.
 (d) Heating mode, inlet/outlet water temperature 40°C/45°C, outdoor air temperature -2°C d.b./-1°C w.b.
 (e) Cooling mode, inlet/outlet water temperature 23°C/18°C, outdoor air temperature 35°C
 (f) Cooling mode, inlet/outlet water temperature 12°C/7°C, outdoor air temperature 35°C

(g) Water outlet temperature 55°C/water temperature heating circuit 35°C
 (h) Water outlet temperature 55°C/water temperature heating circuit 12°C
 (i) Sound pressure values measured at a distance of 4 m in a free field
 (l) Sound pressure values measured at a distance of 1 m in semi-anechoic chamber
 (m) Equipment not hermetically sealed containing fluorinated gases with an equivalent GWP of 2088
 (n) Equipment hermetically sealed containing fluorinated gases with an equivalent GWP of 1430

	7				11				13				13T				16				16T			
	cooling capacity (kW)	Dhw capacity (kW)	Absorption (kW)	EER COP	cooling capacity (kW)	Dhw capacity (kW)	Absorption (kW)	EER COP	cooling capacity (kW)	Dhw capacity (kW)	Absorption (kW)	EER COP	cooling capacity (kW)	Dhw capacity (kW)	Absorption (kW)	EER COP	cooling capacity (kW)	Dhw capacity (kW)	Absorption (kW)	EER COP	cooling capacity (kW)	Dhw capacity (kW)	Absorption (kW)	EER COP
Cooling W7 A35	5,60	0,00	1,81	3,1	8,10	0,00	2,63	3,1	10,40	0,00	3,47	3,0	10,40	0,00	3,47	3,0	11,30	0,00	4,19	2,7	12,80	0,00	4,57	2,8
Dhw W65/W12	0,64	1,28	0,56	2,3	0,64	1,28	0,56	2,3	0,64	1,28	0,56	2,3	0,64	1,28	0,56	2,3	0,64	1,28	0,56	2,3	0,64	1,28	0,56	2,3
Cooling W7 A35 and DHW W65/W12	5,60	1,28	1,55	3,6	8,10	1,28	2,35	3,4	10,40	1,28	3,16	3,3	10,40	1,28	3,16	3,3	11,30	1,28	3,65	3,1	12,80	1,28	4,23	3,0

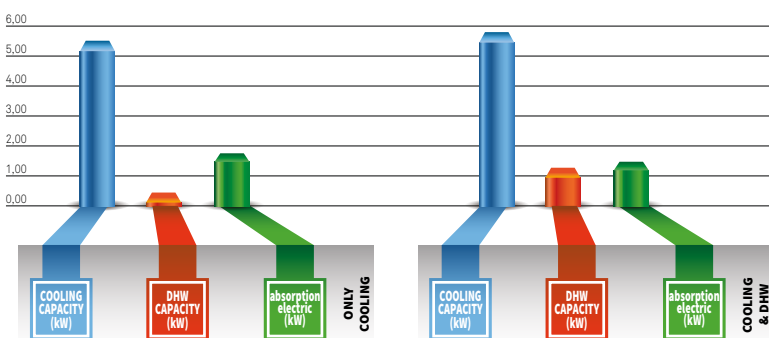

COOLING + DHW WITH ENERGY RECOVERY

During summer operation in cooling mode, the cycle dedicated to DHW production extracts heat from return water from the system circuit.

The cooling requirements of the building is partially satisfied by the DHW cycle and the comfort refrigerating cycle must deliver less power by reducing the speed of the inverter compressor.

The heat taken from the system is recovered in hot water for domestic use.

The efficiency of the integrated system increases (ratio between the energy produced and the energy absorbed from the mains).

LOADING TIME OF BOILERS with 15-65 °C water

The patented Aquadue® double cycle allows rapid loading times of boilers, up to 40% faster than an equally capacious heat pump boiler.*

Aquadue® 7 Loading time of boilers

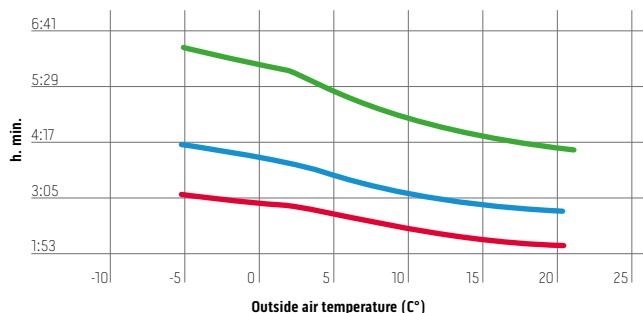

Aquadue® 11 Loading time of boilers

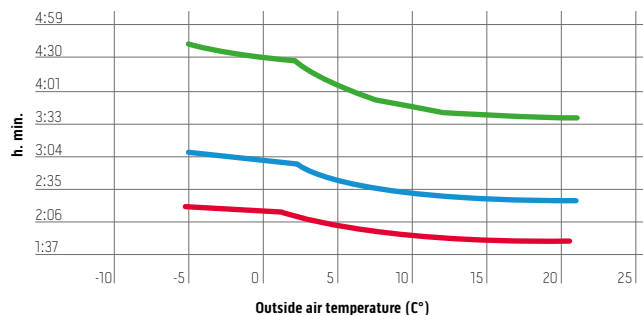

Aquadue® 13/13T Loading time of boilers

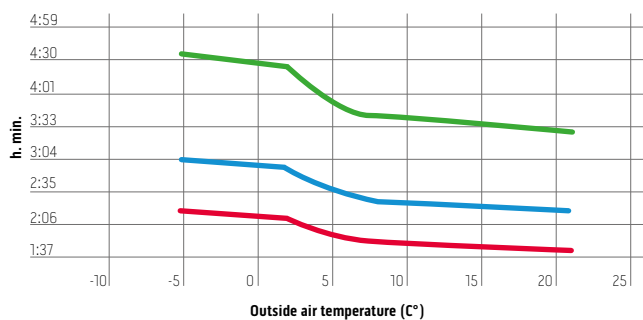

Aquadue® 16 Loading time of boilers

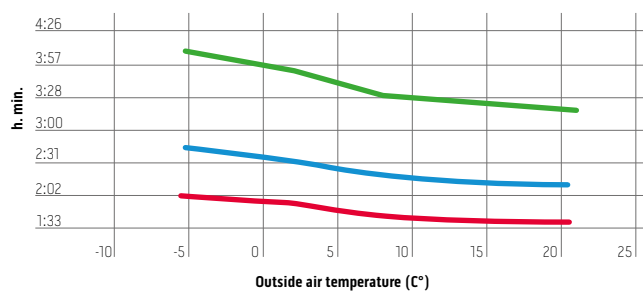

— 300 liters tank
 — 200 liters tank
 — 150 liters tank

INTERNAL UNIT

		AQUADUE 7	AQUADUE 11	AQUADUE 13	AQUADUE 13T	AQUADUE 16	AQUADUE 16T
		SMALL		BIG			
A	mm	500	500	500	500	500	500
B	mm	280	280	280	280	280	280
C	mm	288	288	288	288	288	288
H	mm	1116	1116	1116	1116	1116	1116
Weight	kg	70	70	72	72	72	72

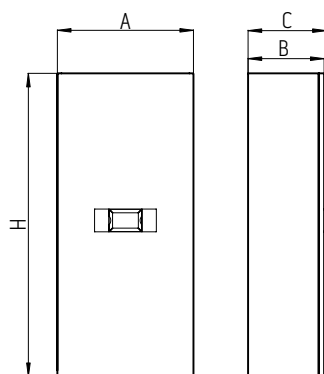

EXTERNAL UNIT S1

		7	11	13	13T	16	16T	
		CESHH24E1	CESHH36E1	CESHH48E1	CESTH48E1	CESHH60E1	CESTH60E1	
		MONO-FAN			BIG			
A	mm	845	946	952	952	952	952	
B	mm	914	1030	1045	1045	1045	1045	
C	mm	540	673	634	634	634	634	
D	mm	363	410	415	415	415	415	
E	mm	350	403	404	404	404	404	
F	mm	915	1036	1032	1032	1032	1032	
H	mm	702	810	1333	1333	1333	1333	
Weight	kg	49	67	95	108	95	113	

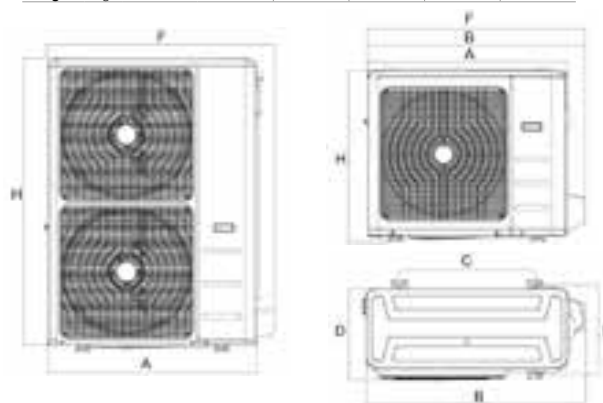

Code B0665 - HEATING CABLE KIT

Prevents the formation of ice on the bottom of the external unit in the event of prolonged operation in particularly severe conditions.

TOUCH SCREEN INTERFACE

SHERPA AQUADUE - SHERPA AQUADUE TOWER

HOME PAGE

The home page shows the following information:

- A - Date and time system
- B - Current Active Mode (Stand-by, cooling, heating, only DHW)
- C - Activated features (climate curve, DHW Turbo, DHW OFF, anti legionella, Night, ECO)
- D - Alarms/overrides (flashing)
- E - Temperature values water system, active system timers, Holiday, Rating
- F - Temperature values DHW water boiler, active timers domestic hot water, Holiday
- G - Activation icons:
 - Mode: operating mode
 - Tset: system and domestic set point
 - Tshow: reading of temperature sensors
 - Timers: time programming
 - Menu: machine functions



OPERATING MODES

Touching the Mode icon, you can access the operating modes configuration page.

The selection icons for all available operating modes are on this page:

- Stand-by, the system is off
- Cooling, the system produces cold water until it reaches the set-point (set point fixed or dynamically defined by climatic curve)
- Heating, the system produces hot water up to the set-point (set point fixed or dynamically defined by climatic curve)
- ECO, energy savings (if climate curve active the ECO set point is not considered)
- Night, the system limits the yield and noise of the outside unit
- Turbo DHW, the system produces hot water using the entire power of the outdoor unit up to the limit set.



SET POINT

Tapping the Tset icon, you can access the configuration page of the set point.

- Cooling water temperature
- ECO cooling water temperature
- Heating water temperature
- ECO heating water temperature
- Domestic hot water temperature (external boiler set point).

The set points for heating and cooling are not considered by the control in the case where the climate curve mode set-point is enabled.

Set point values are changed with a simple touch of the set value.

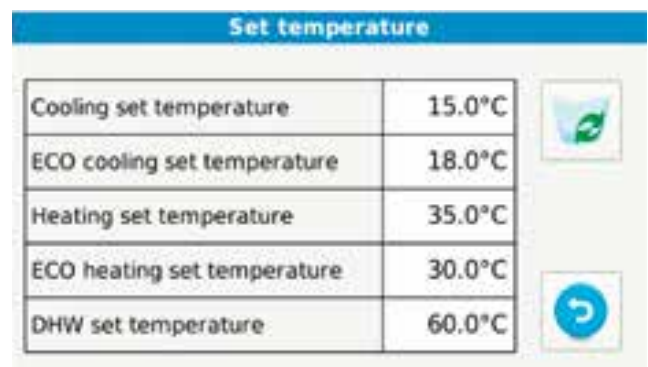

TIMERS

Tapping the Timers icon, you can access available programs.

- Timer heating/cooling
- Timer DHW
- Timer night
- Holidays

Tapping the "Timer Heat/ Cool" or "DHW Timer" or "Timer Night" icon, you can access the page where the activation bands of each timer can be visualized.



PLANT LAYOUTS

SHERPA AQUADUE - SHERPA AQUADUE TOWER

SHERPA AQUADUE heat pump (heating and cooling; high-temperature DHW production); fan coil terminals Bi2 SLR; example of two zone layout with simple manifold and integrated inertial storage tank for the cooling plant.

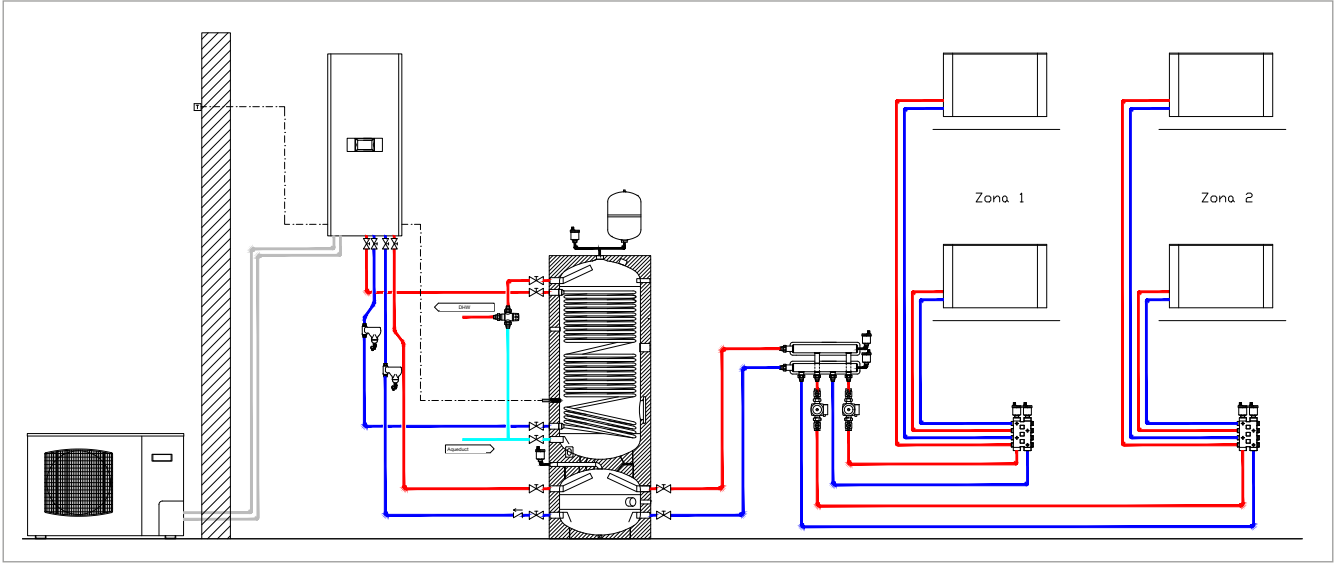

SHERPA AQUADUE heat pump (heating and cooling; high-temperature DHW production); Fan coil terminals Bi2 SLR; example of two zone layout with manifold/separator.

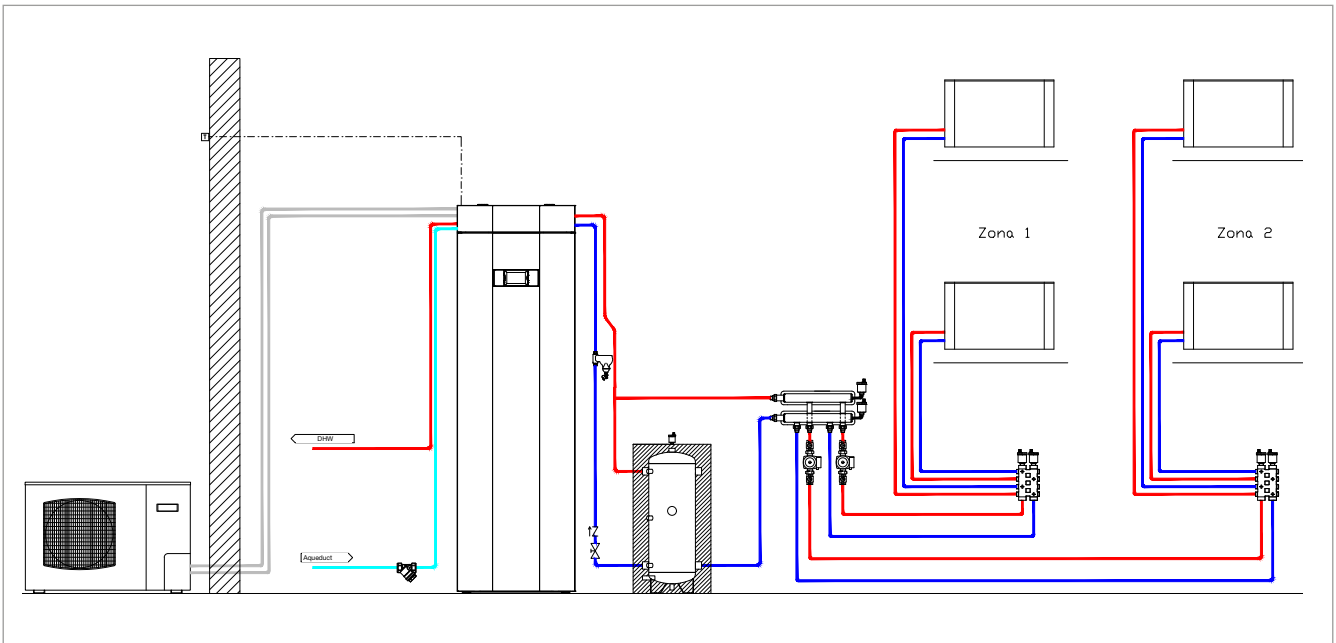

PERFORMANCE AND ENERGY ADVANTAGES



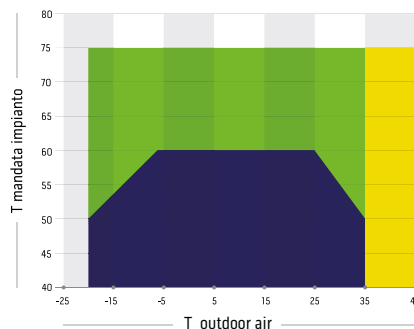

In adverse weather conditions traditional heat pumps decrease thermal output producing water at a lower temperature. Sherpa AQUADUE® as well as extending the area of operation ensures a constant heat output, in the production of Domestic Hot Water.



- **Optimum area of operation of traditional heat pumps**
- **Area of operation extended - AQUADUE® technology**
The double refrigerator circuit allows higher DHW production temperatures thanks to the water-water circuit which are independent of outside air temperature.
- **Heat recovery area - AQUADUE® technology**
in summer cooling operation the refrigeration cycle dedicated to DHW production removes heat from the comfort circuit increasing the overall efficiency of the system.

SHERPA range accessories

SHERPA / SHERPA AQUADUE / SHERPA MONOBLOC

OS Code	Description	Cylinder Capacity litres	puffer Capacity litres	Total height mm	Diameter with insulation mm	insulation mm	Energy Class	Coil exchangers	Coil surfaces Heat Pump mq	Empty weight kg
	01193 Standard cylinder 200 L	200	-	1215	600	50	C 67W	1	1,5	90
	01194 Standard cylinder 300 L	300	-	1615	600	50	C 85W	1	1,8	115
	01804 High-efficiency HE cylinder 200 L	200	-	1215	640	70	B 51W	1 double coil	3,0	120
	01805 High-efficiency HE cylinder 300 L	300	-	1615	640	70	B 63W	1 double coil	4,0	160
	01806 High-efficiency HES solar cylinder 300 L	300	-	1615	640	70	B 63W	1 double coil + 1 solar unit	3,7	140
	01807 Hybrid HY cylinder 300 L	300	80	1925	690	70	B 73W	1	2,8	150
	01808 Hybrid HY solar cylinder 300 L	300	80	1925	690	70	B 73	1+ 1 solar unit	3,3	150
	01199 Heat storage 50 L	-	50	935	400	50	B 34W	-	-	25
	01200 Heat storage 100 L	-	100	1095	500	50	B 50W	-	-	35
	B0618 Resistance for boiler 2 kW									
	B0666 Resistance for boiler 3 kW									
	B0617 Flange resistance kit									

DHW STANDARD CYLINDERS

CYLINDER FOR DOMESTIC HOT WATER PRODUCTION

Cylinder with 1 carbon steel coil, complete with anodic protection, internal vitrification treatment in compliance with DIN 4753-3 and EN 10025 Standards. Insulation: Rigid polyurethane with thickness of 50 mm

energy class **C**

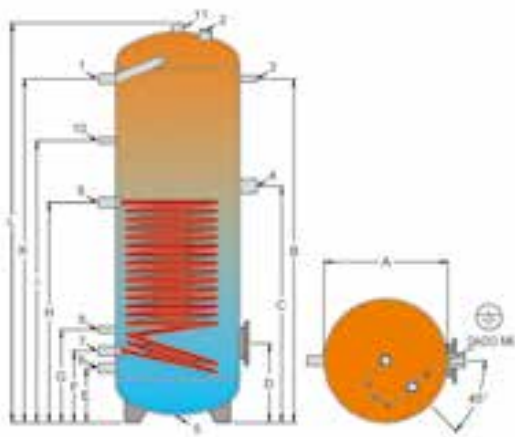

N°	TYPE OF ATTACHMENT	200 ÷ 300
1.	Hot water flow	1"
2.	Anode	1" 1/4
3.	Thermometer-Probe	1/2"
4.	Electric heating element	1" 1/2
5.	Pallet attachment (blind)	1/2"
6.	Cold water inlet	1"
7.	Coil return	1"
8.	Thermostat	1/2"
9.	Coil flow	1"
10.	Recirculation	1/2"
11.	Hot water flow	1" 1/4

Model	A	B	C	D	E	F	G	H	I	J	K	L	M	N
200	500	1000	810	320	220	290	375	750	835	-	975	1215	-	150
300	500	1390	955	320	220	290	375	890	1165	-	1390	1615	-	150

HE/HES HIGH EFFICIENCY DHW CYLINDER

energy class **B**

CYLINDER FOR DOMESTIC HOT WATER PRODUCTION BY HEAT PUMP (HE) AND SOLAR PANELS (HES)

Cylinder with 1 or 2 carbon steel coils with large exchange surface, complete with anodic protection and internal vitrification treatment in compliance with DIN 4753-3 and EN 10025 Standards. Insulation: Rigid polyurethane with thickness of 70 mm.

HE

1 coil cylinder (large surface for heat pump)

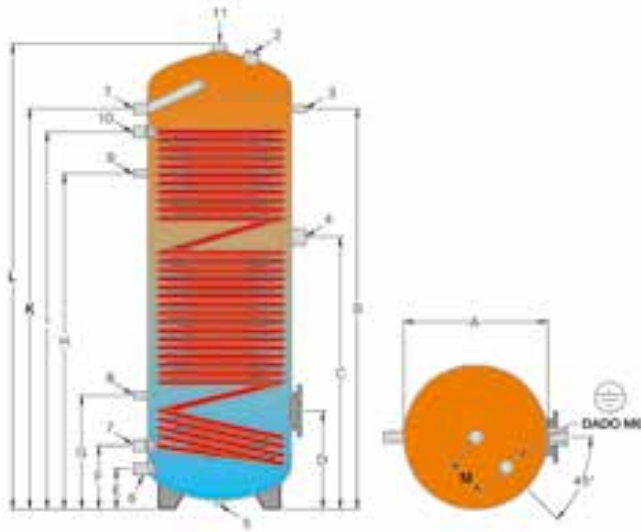

N°	TYPE OF ATTACHMENT	200 ÷ 300
1.	Hot water flow	1"
2.	Anode	1" 1/4
3.	Thermometer-Probe	1/2"
4.	Electric heating element	1" 1/2
5.	Pallet attachment (blind)	1/2"
6.	Water inlet	1"
7.	Coil return	1"
8.	Probe	1/2"
9.	Recirculation	1/2"
10.	Coil flow	1"
11.	Hot water flow	1" 1/4

HES

2 coil cylinder (large surface for heat pump+ solar unit)

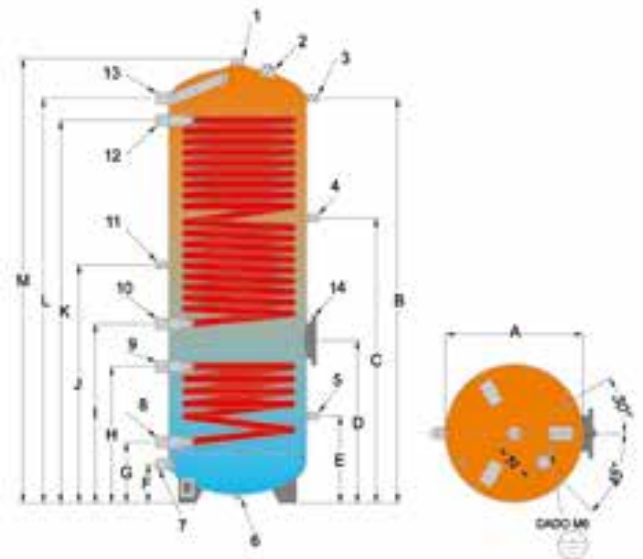

N°	TYPE OF ATTACHMENT	300
1.	Hot water flow	1" 1/4
2.	Anode	1" 1/4
3.	Thermometer-Probe	1/2"
4.	Thermostat	1/2"
5.	Thermostat	1/2"
6.	Pallet attachment (blind)	1/2"
7.	Cold water inlet	1"
8.	Lower coil return	1"
9.	Lower coil flow	1"
10.	Upper coil return	1"
11.	Recirculation	1/2"
12.	Upper coil flow	1"
13.	Hot water flow	1"
14.	Flange with electric heating element attachment	1" 1/2

Model	A	B	C	D	E	F	G	H	I	J	K	L	M	N
HE 200	500	995	735	320	140	220	370	835	990	-	1070	1215	150	-
HE 300	500	1390	945	340	140	220	395	1165	1310	-	1390	1615	150	-
HES 300	500	1470	1035	590	315	140	220	495	650	865	1390	1470	1615	150

SHERPA range accessories

SHERPA / SHERPA AQUADUE / SHERPA MONOBLOC

HYBRID HY/HYS DHW CYLINDERS

energy class **B**

COMBINED HEAT STORAGE UNIT: CYLINDER FOR DOMESTIC HOT WATER PRODUCTION BY HEAT PUMP (HY) AND SOLAR PANELS (HYS) AND INERTIAL STORAGE FOR THE PLANT WATER

Upper cylinder with 1 or 2 carbon steel coils with large exchange surface, complete with anodic protection and internal vitrification treatment in compliance with DIN 4753-3 and EN 10025 Standards. Lower storage tank for heating or cooled water, interior not treated.

Insulation: Rigid polyurethane with thickness of 70 mm

HY
1 coil cylinder
(for heat pump + buffer tank)

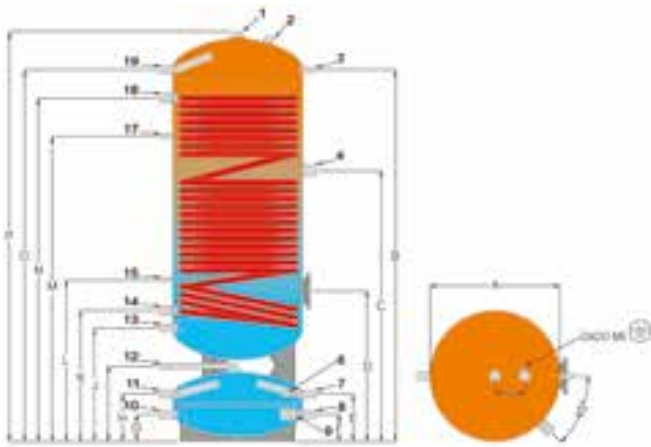

HYS
2 coil cylinder
(for heat pump + solar unit + buffer tank)

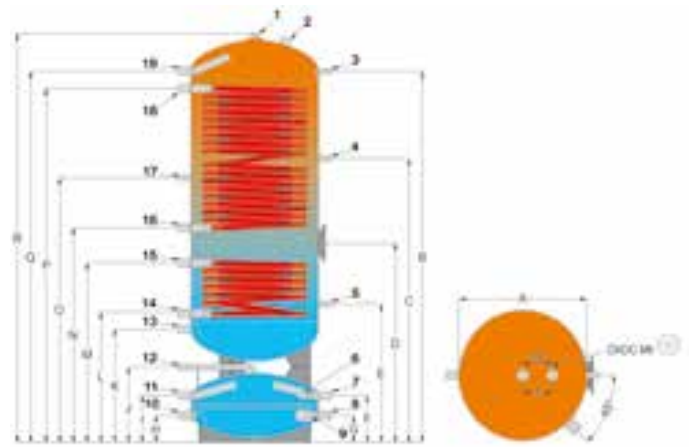

N°	TYPE OF ATTACHMENT	300
1.	Domestic hot water flow	1" 1/4
2.	Anode	1" 1/4
3.	Thermometer	1/2"
4.	Probe	1" 1/2
6.	Probe	1/2"
7.	Boiler flow	1"
8.	Boiler return	1"
9.	Electric heating element	1" 1/2
10.	Heating system return	1"
11.	Heating system flow	1"
12.	Vent	1/2"
13.	Domestic cold water inlet	1"
14.	EBD - Lower coil return	1" 1/4
15.	EBD - Lower coil return	1/2"
17.	Recirculation	1/2"
18.	Upper coil flow	1" 1/4
19.	Domestic hot water flow	1"

N°	TYPE OF ATTACHMENT	300
1.	Domestic hot water flow	1" 1/4
2.	Anode	1" 1/4
3.	Thermometer	1/2"
4.	EBD - Probe	1/2"
5.	EBD - Probe	1/2"
6.	Probe	1/2"
7.	Boiler flow	1"
8.	Boiler return	1"
9.	Electric heating element	1" 1/2
10.	Heating system return	1"
11.	Heating system flow	1"
12.	Vent	1/2"
13.	Domestic cold water inlet	1"
14.	EBD - Lower coil return	1"
15.	EBD - Lower coil return	1"
16.	EBD - Upper coil return	1"
17.	Recirculation	1"
18.	Upper coil flow	1"
19.	Domestic hot water flow	1"

Model	A	B	C	D	E	F	G	H	I	J	K	L	M	N	O	P	Q	R	S
HY 300	550	1755	1300	875	340	160	160	340	505	675	765	940	1425	1675	1755	1925	150	-	-
HYS 300	550	1755	1420	1035	810	340	160	160	340	505	675	755	945	1125	1280	1675	1755	1925	150

HEAT STORAGE TANKS

energy class **B**

BUFFER HEAT STORAGE TANKS

Storage tank for cooled water, interior not treated. Can be used also for heating water.

Insulation: Polyurethane 50 mm

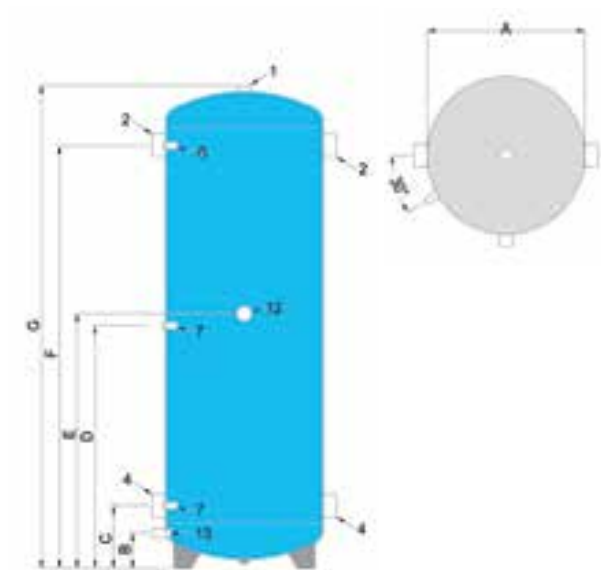

N°	TYPE OF ATTACHMENT	50-100
1.	Vent	1"
2.	boiler flow	1" 1/4
4.	oiler return-heating at 50°C	1" 1/4
5.	oiler return-heating at 30°C	1/2"
6.	thermometer	1/2"
7.	probe	1/2"
12.	Electric heating element	1" 1/2
13.	Drain	1/2"

Model	A	B	C	D	E	F	G
50	300	100	180	485	530	785	935
100	400	100	185	560	605	935	1095

OPTIONAL

ELECTRIC HEATING ELEMENTS

Copper immersion heating element, IP 65, with internal adjustable thermostat and temperature limiter.

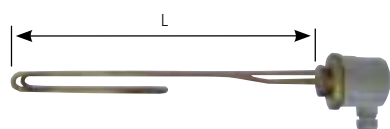

Cod.	W	V	KG	L MM	ATT.
B0618	2000	230	1,5	390	1" 1/2
B0666	3000	230	1,5	390	1" 1/2

FLANGE for HEATING ELEMENT

Mandatory accessory for correct positioning of the electric heating elements if used for anti-legionella cycles.