

NRK 0090-0150

Reversible air/water heat pump

Cooling capacity 18,4 ÷ 31,0 kW
Heating capacity 20,8 ÷ 34,4 kW

- Cooling / heating / high-temperature water production even for DHW production.
- Water produced up to +65 °C
- Heating operations with external temperatures down to -20 °C
- Optimised for heating mode



EUROVENT LCP

DESCRIPTION

Air-cooled outdoor chiller designed to meet air conditioning needs in residential, commercial complexes or industrial applications. The base the structure and the panels are made of steel treated with polyester paint RAL 9003.

VERSIONS

° High efficiency

FEATURES

Operating field

Working at full load up to -20 °C outside air temperature in winter, and up to 48 °C in summer. Hot water production up to 65 °C.

Integrated hydronic kit

Integrated hydronic kit containing the main hydraulic components; available with various configurations with one pumps or storage tank to obtain a solution that allows you to save money and to facilitate installation.

Components

Water filter, flow switch, low and high pressure transducers as standard supply on all units.

Hot water production

In the configuration with desuperheater, it is also possible to produce free-hot water.

DCPX as standard

Phase-cut device that regulates the fan speed to ensure optimum unit operation in all conditions.

CONTROL

MODUCONTROL control type.

The command panel of the unit allows the rapid setting of the working parameters of the machine, and their visualisation. The display consists of 4 figures and various LEDs for indicating the type of operational

mode, the visualisation of the parameters set and of any alarms triggered. The card stores all the default settings and any modifications.

ACCESSORIES

AERNET: The device allows the control, the management and the remote monitoring of a Chiller with a PC, smartphone or tablet using Cloud connection. AERNET works as Master while every unit connected is configured as Slave (max. 6 unit); also, with a simple click is possible to save a log file with all the connected unit datas in the personal terminal for post analysis.

MODU-485BL: RS-485 interface for supervision systems with MODBUS protocol.

MULTICONTROL: Allows the simultaneous control of several units (up to 4), fitted with our MODUCONTROL controller, installed in the same hydraulic system.

PR3: Simplified remote panel. This makes it possible to carry out the unit's basic controls with the signalling of alarms. Can be made remote with shielded cable up to 150 m.

SAF: Thermal buffer tank kit with instantaneous Domestic Hot Water production.

SDHW: Domestic hot water sensor. To be used with a storage tank for the control of water temperature produced.

SPLW: System water temperature sensor. In most cases the loose supplied sensors for each chiller/heat pump are sufficient. In cases of a common flow/return header this sensor can be used to control the common system supply water temperature for the chillers connected to the header, or it can be used for temperature monitoring

VMF-CRP: To predict accessory for the management of the probes SPLW / SDHW if provided with the MULTICONTROL

VT: Antivibration supports

BSKW: Electric heaters kit with IP44 panel for remote mounting in a sheltered area.

■ Refer to the specific "SAF" datasheet for more information about correct system operation, and about the required or recommended accessories. Please consult the VMF system for the production of DHW with a thermal storage tank not supplied by Aermec.

COMPATIBILITY WITH VMF SYSTEM

For more information about VMF system, refer to the dedicated documentation.

FACTORY FITTED ACCESSORIES

DRE: Electronic device for peak current reduction.

ACCESSORIES COMPATIBILITY

Model	Ver	0090	0100	0150
AERNET	°	•	•	•
MODU-485BL	°	•	•	•
MULTICONTROL	°	•	•	•
PR3	°	•	•	•
SAF (1)	°	•	•	•
SDHW (2)	°	•	•	•
SPLW (3)	°	•	•	•
VMF-CRP	°	•	•	•

- (1) For more information about SAF refer to the dedicated documentation.
 (2) Probe required for MULTICONTROL for managing the domestic hot water system.
 (3) Probe required for MULTICONTROL to manage the secondary circuit system.

BSKW: Electric heater kit

Model	Ver	0090	0100	0150
BS6KW400T	°	•	•	•
BS9KW400T	°	•	•	•

BS6KW400T (6kW, 400V 3); BS9KW400T (9kW, 400V 3)

VT: Antivibration

Ver	0090	0100	0150
Integrated hydronic kit: 00, 01, 03, P1, P3			
°	VT15	VT15	VT15

DRE: Device for peak current reduction

Ver	0090	0100	0150
°	DRE10 (1)	DRE10 (1)	DRE15 (1)

- (1) Only for supplies of 400V 3N ~ 50Hz and 400V 3 ~ 50Hz. x 2 or x 3 (if present) indicates the quantity to be ordered.
 A grey background indicates the accessories assembled in the factory

CONFIGURATOR

Field	Description
1,2,3	NRK
4,5,6,7	Size 0090, 0100, 0150
8	Operating field
°	Standard mechanic thermostatic valve (1)
9	Model
H	Heat pump
10	Heat recovery
°	Without heat recovery
D	With desuperheater (2)
11	Version
°	High efficiency
12	Coils
°	Alluminium

- (1) Water produced up to +4 °C.
 (2) The desuperheater can only be used with cold running.

Field	Description
R	Copper-copper
S	Tinned copper
V	Copper-painted aluminium
13	Fans
°	Standard
14	Power supply
°	400V ~ 3N 50Hz
15,16	Integrated hydronic kit
00	Without hydronic kit
01	Storage tank with low head pump
03	Storage tank with high head pump
P1	Single pump low head
P3	Single pump high head

PERFORMANCE SPECIFICATIONS

NRK - (°) / 12/7 °C - 40/45 °C

Size		0090	0100	0150
Cooling performance 12 °C/7 °C(1)				
Cooling capacity	kW	18,4	26,4	31,0
Input power	kW	5,8	8,4	9,8
Cooling total input current	A	13,0	18,0	20,0
EER	W/W	3,19	3,15	3,15
Water flow rate system side	l/h	3172	4546	5338
Pressure drop system side	kPa	19	39	54
Heating performance 40 °C / 45 °C(2)				
Heating capacity	kW	20,8	28,7	34,4
Input power	kW	6,1	8,3	10,3
Heating total input current	A	14,0	17,0	21,0
COP	W/W	3,40	3,45	3,34
Water flow rate system side	l/h	3601	4965	5953
Pressure drop system side	kPa	24	45	65

(1) Data 14511:2018; System side water heat exchanger 12 °C/7 °C; External air 35 °C

(2) Data 14511:2018; System side water heat exchanger 40 °C/ 45 °C; Outside air 7 °C d.b. / 6 °C w.b.

NRK - (°) / 23/18 °C - 30/35 °C

Size		0090	0100	0150
Cooling performance 23 °C/ 18 °C(1)				
Cooling capacity	kW	24,5	34,9	40,9
Input power	kW	6,1	9,0	10,6
Cooling total input current	A	14,0	18,0	22,0
EER	W/W	4,03	3,88	3,86
Water flow rate system side	l/h	4236	6040	7093
Pressure drop system side	kPa	34	69	95
Heating performance 30 °C/ 35 °C(2)				
Heating capacity	kW	20,4	28,2	33,8
Input power	kW	5,0	6,7	8,3
Heating total input current	A	11,0	14,0	17,0
COP	W/W	4,11	4,22	4,09
Water flow rate system side	l/h	3521	4866	5833
Pressure drop system side	kPa	23	43	-

(1) Data 14511:2018; System side water heat exchanger 23 °C/ 18 °C; External air 35 °C

(2) Data 14511:2018; System side water heat exchanger 30 °C/ 35 °C; Outside air 7 °C d.b. / 6 °C w.b.

ENERGY DATA

Size		0090	0100	0150
Cooling capacity with low leaving water temp (UE n° 2016/2281)				
SEER	° W/W	3,35	3,39	3,42
η_{sc}	%	131,10	132,60	133,80
UE 811/2013 average temperature - Pdesignh ≤ 70 kW (1)				
Pdesignh	° kW	22	28	34
SCOP	°	3,03	2,98	2,90
η_{sh}	%	118,00	116,00	113,00
Efficiency energy class	°	A+	A+	A+

(1) Efficiencies for average temperature applications (55°C)

ELECTRIC DATA

Size		0090	0100	0150
Electric data				
Maximum current (FLA)	° A	19,1	24,6	29,5
Peak current (LRA)	° A	104,2	121,2	143,2

GENERAL TECHNICAL DATA

Size			0090	0100	0150
Compressor					
Type	°	type	Scroll	Scroll	Scroll
Compressor regulation	°	Type	On-Off	On-Off	On-Off
Number	°	no.	1	1	1
Circuits	°	no.	1	1	1
Refrigerant	°	type	R410A	R410A	R410A
Refrigerant charge	°	kg	13,0	14,0	16,0
System side heat exchanger					
Type	°	type	Plates	Plates	Plates
Number	°	no.	1	1	1
Hydraulic connections					
Connections (in/out)	°	Type	Gas-F	Gas-F	Gas-F
Diametre (in)	°	Ø	1½"	1½"	1½"
Diametre (out)	°	Ø	1½"	1½"	1½"
Fan					
Type	°	type	axials	axials	axials
Fan motor	°	type	On-Off	On-Off	On-Off
Number	°	no.	2	2	2
Air flow rate	°	m³/h	14200	14200	13700
Sound data calculated in cooling mode (1)					
Sound power	°	dB(A)	78,0	78,0	78,0
Sound pressure level (10 m)	°	dB(A)	46,5	46,5	46,5

(1) Sound power calculated on the basis of measurements made in accordance with UNI EN ISO 9614-2, as required for Eurovent certification. Sound pressure (cold functioning) measured in free field, 10m away from the unit external surface (in compliance with UNI EN ISO 3744).

DIMENSIONS

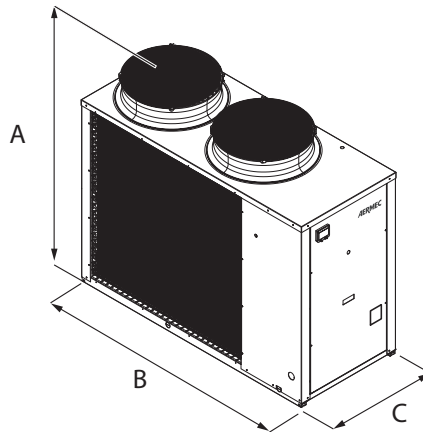

Size			0090	0100	0150
Dimensions and weights					
A	°	mm	1450	1450	1450
B	°	mm	1750	1750	1750
C	°	mm	750	750	750
Weight empty	°	kg	289	328	372

Aermec reserves the right to make all modification deemed necessary for improving the product at any time with any modification of technical data.

Aermec S.p.A.

Via Roma, 996 - 37040 Bevilacqua (VR) - Italia
Tel. 0442633111 - Telefax 044293577
www.aermec.com